

RENTAL CATALOG

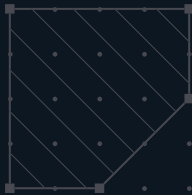

TELESCOPIC BOOM LIFT

JLG 460SJ



About Us

Built by contractors, for contractors.

Founded in 2015 by construction industry veterans Jabbok and Willy Schlacks, EquipmentShare® is reshaping the built environment by empowering the industries that build our world. Our mission is to deliver innovative tools and technology that enhance productivity, safety and efficiency on every jobsite

Decades of experience in construction have shaped our culture to be obsessive about delivering tangible value. We solve our customers' challenges with incredibly responsive support and cutting-edge technology, building for the modern era. With our nationwide network and advanced fleet management platform, T3, we offer a smarter, faster way to rent and manage equipment while giving you total control and visibility over your assets, people and resources.

Today, EquipmentShare is the fastest-growing equipment solutions provider in the U.S., with over 6,000 team members, 270 locations and 241,000 connected assets. Join us as we redefine what's possible across the built environment with next-generation equipment and leading fleet management solutions.





Equipment Share

Equipment Share
A Division of
/ / / / /
(888) 80-REIS
equipmentshare.com

TABLE OF CONTENTS

INTRODUCTION	T3	06
AERIAL WORK PLATFORMS	Scissor Lifts	12
	Telescopic Boom Lifts	14
	Articulating Boom Lifts	16
	Atrium, Towable, Pusharound and Vertical Mast Lifts	17
	ROM and Lift Performance Graphs	18
AGRICULTURE AND LANDSCAPING	Trenchers	22
	Stump Grinders	22
	Brush Chippers	23
	Vacuum Excavators	24
	Utility Vehicles and Burden Carriers	25
COMPACTION	Single Drum Rollers	27
	Trench Rollers	27
	Double Drum Rollers	28
	Light Duty Compaction	29
CONCRETE AND MASONRY	Concrete Buggies	32
	Concrete Mixers and Placement	33
	Concrete Prep and Finishing	34
	Cutting and Coring	35
EARTHMOVING	Compact Track Loaders	38
	Track Dozers	40
	Backhoe and Skip Loaders	42
	Mini Excavators	44
	Track Excavators	46
	Wheeled Skid Loaders	48
	Wheel Loaders	50
	Motor Graders	52
FORKLIFTS AND MATERIAL HANDLING	Telehandlers	56
	Carry Deck Cranes	57
	Industrial Forklifts	58
	Electric and Manual Material Handling	59
	ROM and Lift Performance Graphs	60
LIGHTING AND SECURITY	General Construction Lighting	64
	Security Systems	65
	Solar Light Plants and Light Carts	66
	Towable Light Plants	67
SAFETY, TESTING AND COMMUNICATION		69
SURFACE PREPARATION AND CLEANING	Pressure Washers	71
	Sweepers and Scrubbers	72
	Jobsite Sweepers	73
VEHICLES AND TRAILERS	Water Trucks and Dump Trucks	75
	Rental Trailers	76
	Rental Vehicles	77
CLIMATE CONTROL	Portable Air Conditioning	82
	Industrial Air Conditioning	83
	Air Handlers	84
	Chillers	85
	Dehumidifiers	86
	Fans	87
	Air Scrubbers	88
	Heaters	89
EVENT AND SITE SERVICES		91

FLUID SOLUTIONS	Centrifugal Pumps	94
	Diaphragm Pumps	96
	Submersible Pumps	97
	Hydraulic Submersible Pumps and Hydraulic Power Packs	98
	Wellpoint Dewatering Pumps	99
	Self Contained Mobile Duty Variable Frequency Drives	100
	Accessories	101
	<hr/>	
POWER SOLUTIONS	Generators	104
	Portable Generators	105
	Panels	106
<hr/>		
MOBILE TOOL TRAILERS		110
<hr/>		
COMPRESSED AIR	Air Compressors	114
	Compressed Air Tools	115
<hr/>		
ELECTRIC AND HYDRAULIC POWER TOOLS		118
<hr/>		
ATTACHMENTS	Compact Track and Skid Loader	122
	Excavator	123
	Wheel Loader	124
	Material Handling	125
<hr/>		
STORAGE TANKS AND CONTAINERS	Connex Boxes	127
	Fluid Tanks	127
	Fuel Cells	128
	Job Box	129

WELDING, CUTTING AND PIPE FABRICATION	Engine Driven Welders	132
	Electric Welders	132
	Suitcase Welders	133
	Inverter Welders	133
	Plasma Cutters	134
	Welding Accessories	135
	Pipe Threading	136
	Pipe Beveling	137
<hr/>		
INDUSTRIAL GOODS		138
<hr/>		
LEIF ASSURANCE - CONSTRUCTION INSURANCE		140
<hr/>		
BEVEL FINANCIAL		141
<hr/>		
LOCATIONS LIST		142

DIVISIONS

 **ADVANCED SOLUTIONS**

 **CORE SOLUTIONS**

 **TOOLING SOLUTIONS**

*Icons indicate which division each section falls under.

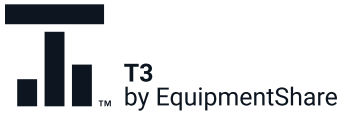

THERE'S A BETTER WAY TO RENT.

T3 combines industry-leading hardware and software to successfully manage all your rentals.

Control Costs

- On/Off-rent equipment directly from the app to avoid unnecessary charges.
- Minimize service events with proactive maintenance and real-time diagnostics from our service technicians.
- Streamline billing with instant, direct invoicing for transparent and accurate charges.

Maximize Rental Utilization

- Gain in-the-moment insights into location, status, usage and delivery status.
- Access over 70 customizable reports.

Enhance Visibility

- Monitor your entire rental and owned fleet on a single page.
- Track live locations, statuses and delivery updates of all assets 24/7, from anywhere.

Improve Access Control

- Use the T3 Cloud-Connected Keypad to manage access and prevent theft.
 - Set up geofencing and receive alerts for unauthorized usage.
-



Interested in learning how T3 can work for more than your rentals?

Scan the code to schedule a demo with a T3 sales person. Together, we'll discuss the T3 solution that's right for your team.



Keypad

USERS WITH ACCESS:
CODY, ALEX, JAMIE
LAST TRIP: 4:57PM
LAST USER: ALEX



ON SITE

TYPE: SCISSOR LIFT
HOURS: 980
BATTERY: LOW

Asset Utilization

08/08/2024 - 08/22/2024

DAYS USED: 11
DAYS IDLE: 4
APPROX. USAGE: 2 DAYS

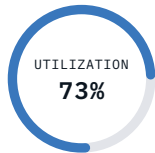





 CORE SOLUTIONS

Aerial Work Platforms

Agriculture and Landscaping

Compaction

Concrete and Masonry

Earthmoving

Forklifts and Material Handling

Lighting and Security

Safety, Testing and Communication

Surface Preparation and Cleaning

Vehicles and Trailers

AERIAL WORK PLATFORMS

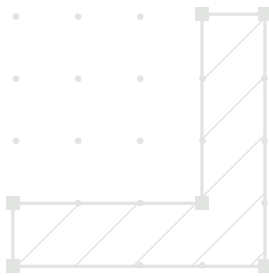
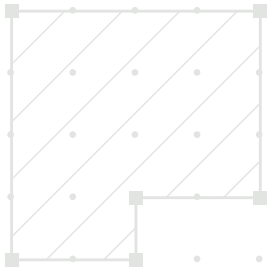
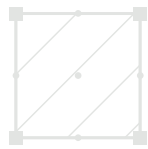



ARTICULATING BOOM LIFT

JLG 450AJ



SCISSOR LIFTS - ELECTRIC AND INTERNAL COMBUSTION

CLASS	MODEL		MAX PLATFORM HEIGHT	PLATFORM CAPACITY	EXTENDED PLATFORM SIZE	WEIGHT	OVERALL WIDTH
Electric Scissor Lift, 10'-12'	HYBRID 1030	⚡	10'	800 lbs	2' 6"	1,273 lbs	30"
Electric Scissor Lift, 13'-14' Micro	MEC 1330	⚡	13'	500 lbs	2'	2,050 lbs	31.5"
Electric Scissor Lift, 19' Narrow	SKYJACK SJIII3219	⚡	19'	550 lbs	3'	2,580 lbs	32"
Electric Scissor Lift, 19' Micro	MEC Micro 19	⚡	15'	500 lbs	2'	2,860 lbs	32"
Electric Scissor Lift, 19' Micro with Step-up Platform	MEC Micro 19-XD	⚡	19' + 20"	500 lbs	2' Xtra-Deck Width: 1' 10"	2,820 lbs	32"
Electric Scissor Lift, 26' Narrow	SKYJACK SJIII3226	⚡	26'	500 lbs	3'	4,135 lbs	32"
Electric Scissor Lift, 26' Micro	MEC Micro 26	⚡	26'	500 lbs	3'	4,190 lbs	31.9"
Electric Scissor Lift, 26' Wide	SKYJACK SJIII4726	⚡	25' 8"	700 lbs	4'	5,537 lbs	47"
Electric Scissor Lift, 32' Narrow	GENIE GS-3232	⚡	32' 1"	500 lbs	3'	5,367 lbs	32"
Electric Scissor Lift, 32' Wide	SKYJACK SJIII4732	⚡	31' 8"	700 lbs	4'	5,496 lbs	47"
Electric Scissor Lift, 40' Narrow	SKYJACK SJIII4740	⚡	39' 5"	500 lbs	3'	4,780 lbs	47"
Electric Scissor Lift, 40' Wide	JLG E4069	⚡	40' 3"	800 lbs	3' 6"	10,558 lbs	69"
Electric Scissor Lift, 45'-46'	MEC 4555	⚡	45'	500 lbs	2' 11"	7,760 lbs	55"
Rough Terrain Scissor Lift, 26'-29'	SKYJACK SJ6826 RT		26'	1,250 lbs	5'	6,460 lbs	69.5"
Rough Terrain Scissor Lift, 30'-35'	SKYJACK SJ6832 RT		38'	1,000 lbs	5'	7,590 lbs	69.5"
Rough Terrain Scissor Lift, 30'-35' Wide Deck	GENIE GS-3390 RT		33'	2,500 lbs	5'	11,977 lbs	92"
Rough Terrain Scissor Lift, 36'-45'	GENIE GS-4069 RT		40' 3"	800 lbs	5'	10,392 lbs	69"
Rough Terrain Scissor Lift, 36'-45' Wide Deck	GENIE GS-4390 RT		43'	1,500 lbs	5'	12,894 lbs	92"
Rough Terrain Scissor Lift, 50'-55' Wide Deck	GENIE GS-5390 RT		53'	1,500 lbs	5'	16,567 lbs	92"
Rough Terrain Scissor Lift, 60'-65' Wide Deck	MEC 6092 RT		60'	1,200 lbs	7' 3"	21,780 lbs *may vary	92"

⚡ * Electric Powered Assets



GENIE
GS-1930



GENIE
GS-2646



MEC
1330SE

SCISSOR LIFTS - ELECTRIC AND INTERNAL COMBUSTION (CONTINUED)

CLASS	MODEL	MAX PLATFORM HEIGHT	PLATFORM CAPACITY	EXTENDED PLATFORM SIZE	WEIGHT	OVERALL WIDTH
Electric Rough Terrain Scissor Lift, 36'–45' Wide Deck	HAULOTTE HS4390 E PRO	⚡ 42' 8"	1,654 lbs	3' 3"	16,577 lbs	91"
Hybrid Rough Terrain Scissor Lift, 50'–55' Wide Deck	HAULOTTE HS5390 E PRO	⚡ 52' 6"	1,654 lbs	3' 3"	17,746 lbs	91"
Electric Scissor Lift, 19' Narrow	GENIE GS-1930	⚡ 19' 3"	500 lbs	2' 11.8"	3,209 lbs	30"
Electric Scissor Lift, 26' Narrow	GENIE GS-2632	⚡ 26' 1"	500 lbs	3'	4,729 lbs	32"
Electric Scissor Lift, 26' Wide	GENIE GS-2646	⚡ 26' 1"	1,000 lbs	3'	4,346 lbs	46"
Electric Scissor Lift, 40' Narrow	GENIE GS-4046 E Drive	⚡ 39' 2"	770 lbs	3'	6,871 lbs	46"
Electric Scissor Lift, 13'–14'	MEC 1330SE	⚡ 13'	530 lbs	2'	2,050 lbs	31.5"



TELESCOPIC BOOM LIFTS - INTERNAL COMBUSTION				
CLASS	MODEL	MAX PLATFORM HEIGHT	CAPACITY	PLATFORM SIZE
Telescopic Boom Lift, 40' IC	JLG 400S ⓘ	40'	Restricted: 1,000 lbs Unrestricted: 600 lbs	3' x 8'
Telescopic Boom Lift, 45'-46' IC	JLG 460SJ	46'	Restricted: 1,000 lbs Unrestricted: 600 lbs	3' x 8'
Telescopic Boom Lift, 60' IC	JLG 600S ⓘ	59' 8"	Restricted: 1,000 lbs Unrestricted: 600 lbs	3' x 8'
Telescopic Boom Lift, 65'-66', Electric	JLG EC600SJ ⓘ ⚡	60' 3"	500 lbs	2' 6" x 6'
Telescopic Boom Lift, 65'-67' IC	JLG 660SJ	65' 8"	Restricted: 750 lbs Unrestricted: 550 lbs	3' x 8'
Telescopic Boom Lift, 80' IC	JLG 800S	80'	Restricted: 1,000 lbs Unrestricted: 500 lbs	3' x 8'
Telescopic Boom Lift, 85'-86' IC	JLG 860SJ	86'	Restricted: 750 lbs Unrestricted: 500 lbs	3' x 8'
Telescopic Boom Lift, 120'-125' IC	JLG 1200SJP ⓘ	120'	Restricted: 1,000 lbs Unrestricted: 500 lbs	3' x 8'
Telescopic Boom Lift, 135' IC	JLG 1350SJ	135'	Restricted: 1,000 lbs Unrestricted: 500 lbs	3' x 8'
Telescopic Boom Lift, 150' IC	JLG 1500SJ	150'	Restricted: 1,000 lbs Unrestricted: 500 lbs	3' x 8'
Telescopic Boom Lift, 180'-185' IC	JLG 1850SJ	185' 7"	Restricted: 1,000 lbs Unrestricted: 500 lbs	3' x 8'

⚡ * Electric Powered Assets

ⓘ * More Info on pg. 18



JLG
1200SJP



JLG
1350SJ



GENIE
S-65 XC

TELESCOPIC BOOM LIFTS - INTERNAL COMBUSTION (CONTINUED)

CLASS	MODEL	MAX PLATFORM HEIGHT	CAPACITY	PLATFORM SIZE
Trax Tracked Telescopic Boom Lift, 40' - 46' IC	GENIE S45	44' 6"	Restricted: 1,000 lbs Unrestricted: 600 lbs	3' / 2' 6" x 8' / 6'
Trax Tracked Telescopic Boom Lift, 60' - 70' IC	GENIE S-65 XC ⓘ	65' 2"	Restricted: 1,000 lbs Unrestricted: 600 lbs	3' / 2' 6" x 8' / 6'



GENIE
Z-34/22 IC



GENIE
Z-40/23N RJ



JLG
450AJ

ARTICULATING BOOM LIFTS - INTERNAL COMBUSTION, HYBRID AND ELECTRIC

CLASS	MODEL	MAX PLATFORM HEIGHT	CAPACITY	PLATFORM SIZE
Articulating Boom Lift, 30'-35' IC	GENIE Z-34/22 IC	34' 7"	500 lbs	2' 6" x 4' 8"
Articulating Boom Lift, 40'-45' IC	GENIE Z-45 IC	45'	500 lbs	2' 5" x 6'
Articulating Boom Lift, 60'-65' IC	GENIE Z-62/40 ⓘ	61' 11"	500 lbs	3' 2' 6" x 8' 6"
Articulating Boom Lift, 80'-85' IC	GENIE Z-80/60 ⓘ	78'	500 lbs	3' 2' 6" x 8' 6"
Articulating Boom Lift, 125' IC	JLG 1250AJP	125'	500 lbs	3' x 8'
Articulating Boom Lift, 135' IC	GENIE Z-135/70	135'	Unrestricted: 600 lbs	3' 2' 6" x 8' 6"
Articulating Boom Lift, 150' IC	JLG 1500AJP	150'	600 lbs	3' x 8'
Hybrid Articulating Boom Lift, 60'-65'	GENIE Z-60 FE ⚡	59' 7"	500 lbs	3' 2' 6" x 8' 6"
Electric Articulating Boom Lift, 30'-34'	GENIE Z-30/20N RJ ⚡	29' 2"	500 lbs	2' 6" x 3' 10"
Electric Articulating Boom Lift, 30'-34'	JLG E300AJPN ⚡	29' 5"	500 lbs	2' 6" x 4'
Electric Articulating Boom Lift, 40' Narrow	JLG E400AJPN ⚡	40'	500 lbs	2' 6" x 4'
Electric Articulating Boom Lift, 40' Narrow	GENIE Z-40/23N RJ ⚡	40' 5"	500 lbs	2' 6" x 3' 10"
Electric Articulating Boom Lift, 45' Wide	JLG E450AJ ⓘ ⚡	45'	500 lbs	2' 6" x 5'

⚡ * Electric Powered Assets

ⓘ * More Info on pg. 19



GENIE
AWP-30S



GENIE
GR-20

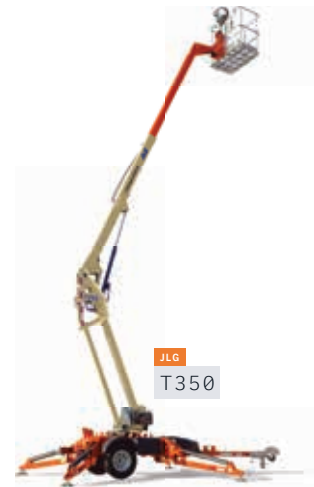

JLG
T350

ATRIUM, TOWABLE, PUSHAROUND AND VERTICAL MAST LIFTS

CLASS	MODEL		MAX PLATFORM HEIGHT	CAPACITY	PLATFORM SIZE
Atrium Lift, 60'–65'	JLG X600AJ	⚡	59' 3"	500 lbs	2' 6" x 4' 7"
Atrium Lift, 70'–80'	JLG X770AJ	⚡	77' 5"	500 lbs	4' 10" x 2' 6"
Atrium Lift, 100'	JLG X1000AJ	⚡	100'	500 lbs	5' 3" x 2' 4"
Towable Boom Lift, 30'–35'	HAULOTTE 3522 A	⚡	35' 9"	500 lbs	4' 1" x 2' 9"
Towable Boom Lift, 50'	HAULOTTE 5533 A	⚡	55' 3"	500 lbs	4' 1" x 2' 9"
Hybrid Towable Boom Lift, 50'	GENIE TZ-50	⚡	49' 6"	500 lbs	2' 2.8" x 3' 8"
Pusharound Vertical Mast Lift, 10'–20'	JLG 1030 P	⚡	10' 2"	550 lbs	5' x 2' 6"
Pusharound Vertical Mast Lift, 30'	GENIE AWP-30S	⚡	29' 6"	350 lbs	2' 3" / 2' 2" / 3' 8.8"
Pusharound Vertical Mast Lift, 40'	GENIE AWP-40S	⚡	40' 3"	300 lbs	2' 3" / 2' 2" / 3' 8.8"
Vertical Mast Lift Single Operator, 15'–16'	GENIE GR-15	⚡	14' 8"	500 lbs	4' 7" x 2' 5.5"
Vertical Mast Lift Single Operator, 20'	GENIE GR-20	⚡	19' 9"	350 lbs	4' 7" x 2' 5.5"
Vertical Mast Lift with Jib, 26'	JLG Toucan 26E	⚡	26' 5"	500 lbs	2' 5" x 3'
Vertical Mast Lift with Jib, 32'	JLG Toucan 32E	⚡	32' 3"	500 lbs	2' 4" x 3' 5"
Towable Boom Lift, 30'–35'	JLG T350	⚡	34' 5"	500 lbs	2' 6" x 4'
Towable Boom Lift, 50'	JLG T500J ⓘ	⚡	31' 6"	500.4 lbs	2' 5" x 4'

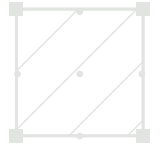

RANGE OF MOTION & LIFT PERFORMANCE

Telescopic, Articulating and Towable Boom Lifts



Telescopic Boom Lift
JLG 400S

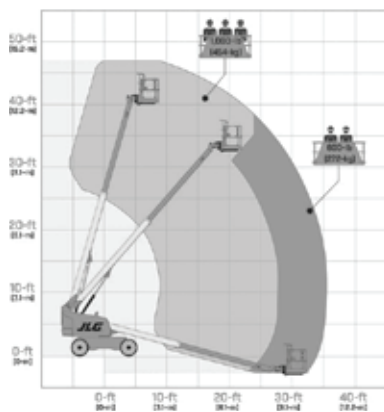

Telescopic Boom Lift
JLG 600S

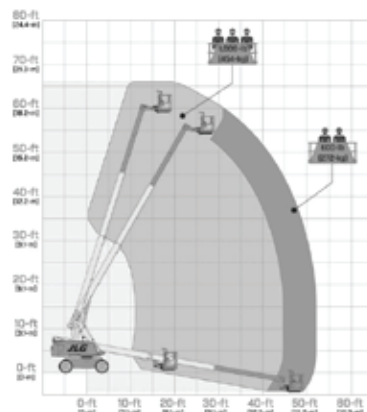

Telescopic Boom Lift
JLG EC600SJ

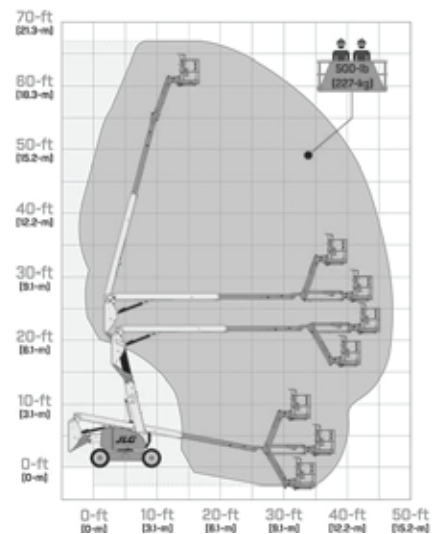

Telescopic Boom Lift
JLG 1200SJ

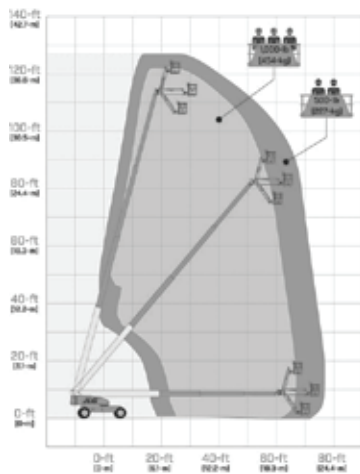

Telescopic Boom Lift
GENIE S-65 XC

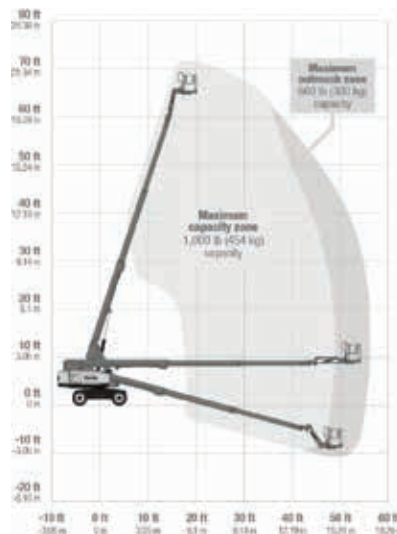

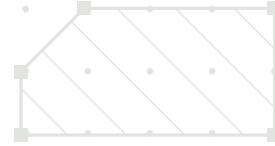

Articulating Boom Lift
GENIE Z-62/40

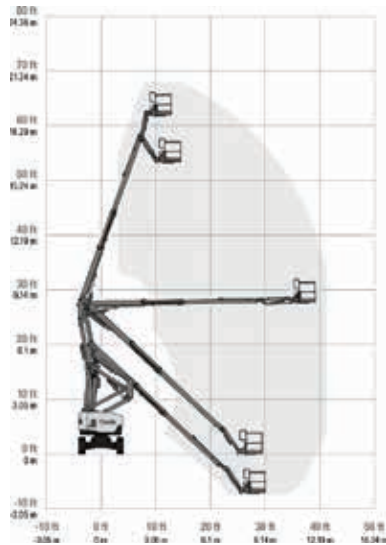

Articulating Boom Lift
GENIE Z-80/60

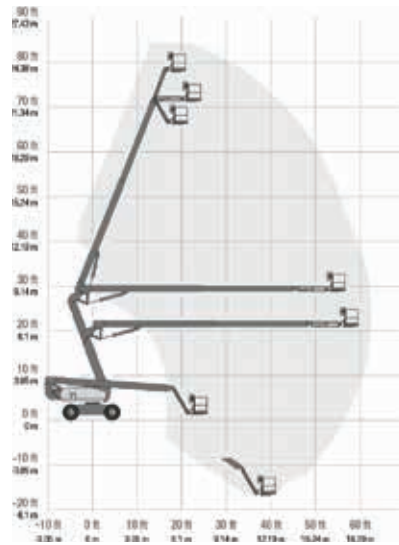

Articulating Boom Lift
JLG E450AJ

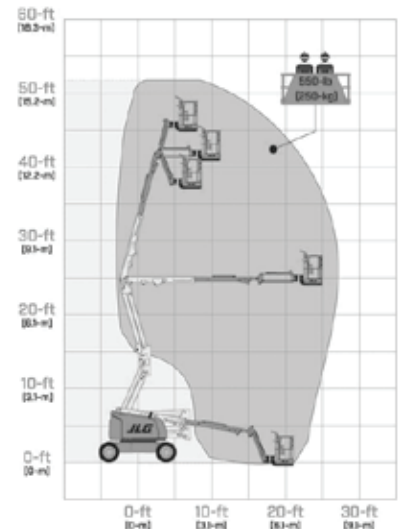

Towable Boom Lift
JLG T500J

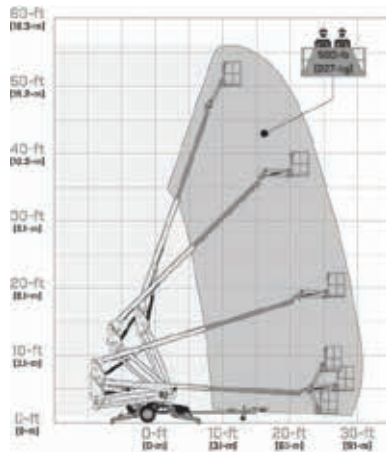

AGRICULTURE AND LANDSCAPING

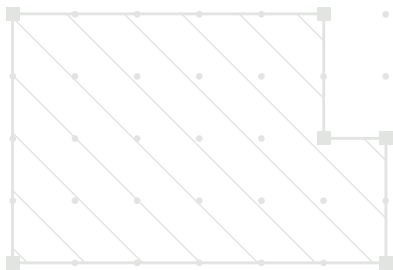
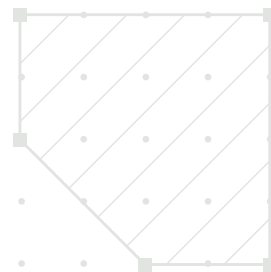

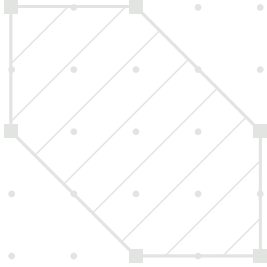
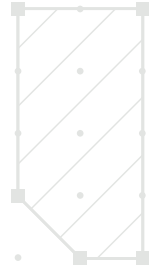

VACUUM EXCAVATOR

VERMEER VX50-500

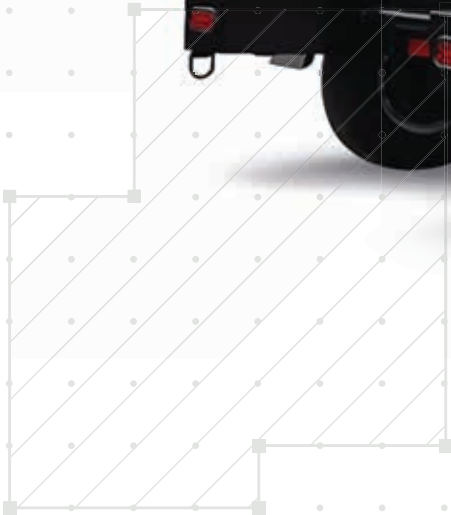



TORO
TRX-250



BARRETO
912HM



VERMEER
RTX450

TRENCHERS

CLASS	MODEL	HORSEPOWER	WEIGHT
Tracked Walk Behind Trencher	TORO TRX-250	24.5 hp	1,104 lbs
Wheeled Walk Behind Trencher	BARRETO 912HM	8.5 hp	620 lbs
Ride-On Trencher	VERMEER RTX450	49 hp	4,507 lbs



BARRETO
ES30SGB

STUMP GRINDERS

CLASS	MODEL	HORSEPOWER	CAPACITY
Walk-Behind Stump Grinder, 30 - 40 HP	BARRETO ES30SGB	30-40 hp	1,700 lbs



VERMEER
BC700XL



VERMEER
BC1000XL

BRUSH CHIPPERS

CLASS	MODEL	TOP FEED SPEED	INFEED THROAT CAPACITY	BLADE LENGTH: TABLE DOWN, TONGUE EXTENDED
Chipper 6", Gas	Vermeer BC700XL Gas	49.4'/min	6" x 8"	136"
Chipper 12", Diesel	Vermeer BC1000XL Diesel	105'/min	12" x 17"	208"
Chipper 12", Gas	Vermeer BC1000XL Gas	118'/min	12" x 17.5"	208"



VACUUM EXCAVATORS

CLASS	MODEL
Vacuum Excavator 500–600 CFM, Gas	VERMEER CV573GT
Vacuum Excavator 500–600 CFM, Diesel	VERMEER LP573XDT
Vacuum Excavator 1,000 CFM, Diesel	VERMEER VX50-500



UTILITY VEHICLES AND BURDEN CARRIERS

CLASS	MODEL	TOP SPEED	SEATING CAPACITY	TOWING CAPACITY
Utility Vehicle 2-3 Passenger, Gas	KUBOTA RTV-XG850	40 mph	2	flat: 2,000 lbs slope: 1,550 lbs
Utility Vehicle 2-3 Passenger, Diesel	YANMAR YU1000	30 mph	2-3	2,000 lbs
Utility Vehicle 4-6 Passenger, Gas	KAWASAKI MULE FE	25 mph	2	1,200 lbs
Utility Vehicle 4-6 Passenger, Diesel	PRO XD 4000D AWD	26 mph	4	1,250 lbs
Utility Vehicle 3-4 Passenger, Electric	CLUB CAR CA100E ⚡	17 mph	3-4	850 lbs
4 Wheel Burden Carrier, Electric	TAYLOR DUNN R-380 ⚡	15 mph	2	5,000 lbs
3 Wheel Burden Carrier, Electric	TAYLOR DUNN SS-536 ⚡	9 mph	2	2,000 lbs

⚡ * Electric Powered Assets

COMPACTION



TRENCH ROLLER

WACKER NEUSON RTK_x-SC3



SINGLE DRUM ROLLERS

CLASS	MODEL	TYPE	OPERATING WEIGHT	FUEL TANK CAPACITY	GRADEABILITY	DRUM WIDTH
Ride-On Single Drum Roller, 5 – 6 Ton, 54" Width	WACKER NEUSON RC50	One Way	11,364.80 lbs	32.5 gal	55% (max. w/o vibration: 60%)	53.9"
Ride-On Single Drum Roller, 7 – 8 Ton, 66" Width	WACKER NEUSON RC70	One Way	14,418.20 lbs	32.5 gal	60% (w/o vibration)	66.1"
Ride-On Single Drum Roller, 7 – 8 Ton, 66" Width	CASE SV207E	One Way	15,400 lbs	34.34 gal	59% (w/o traction assist)	66.1"
Ride-On Single Drum Roller, 10 – 12 Ton, 84" Width	DYNAPAC CA2500D	One Way	22,266.70 lbs	71.9 gal	51%	84"



TRENCH ROLLERS

CLASS	MODEL	TYPE	OPERATING WEIGHT	FUEL TANK CAPACITY	GRADEABILITY	DRUM WIDTH
Walk-Behind Trench Roller, 24 – 34", Pad	WACKER NEUSON RTKx-SC3	Remote Controlled	3,235 lbs	6.3 gal	50%	22"



WACKER NEUSON
RD12A



DYNAPAC
CC1200VI

DOUBLE DRUM ROLLERS

CLASS	MODEL	TYPE	OPERATING WEIGHT	FUEL TANK CAPACITY	GRADEABILITY
Ride-On Double Drum Roller, 1.5 Ton, 36" Width	WACKER NEUSON RD12A	One Way	2,586 lbs	6.5 gal	30%
Ride-On Double Drum Roller, 3 Ton, 48" Width	DYNAPAC CC1200 VI	Reversible	5,974.527 lbs	13.2 gal	43%



LIGHT DUTY COMPACTION

CLASS	MODEL	TYPE	OPERATING WEIGHT
Reversible Plate Compactor, Diesel	WACKER NEUSON DPU4545	Reversible	932.5 lbs
Reversible Plate Compactor, Gas	MULTIQUIP MVH405GH	Reversible	836 lbs
Vibratory Plate Compactor	WACKER NEUSON WP1550AW	Reversible	196.2 lbs
Jumping Jack Rammer, 2,900 – 3,600 lbs/Blow	DYNAPAC DR7X	Reversible	150 lbs
Jumping Jack Rammer, 2,500 – 3,600 lbs/Blow	WACKER NEUSON BS60-4As	Reversible	158 lbs

CONCRETE AND MASONRY

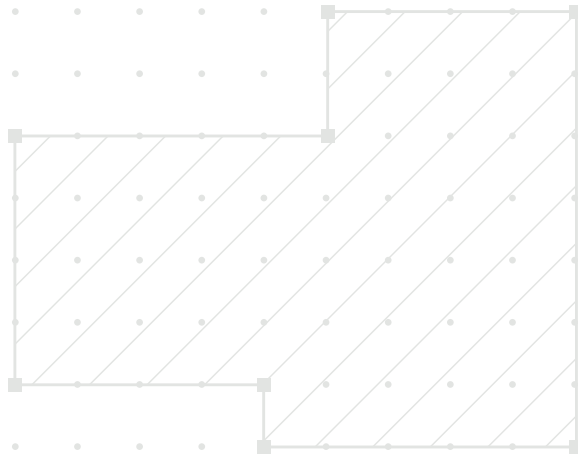
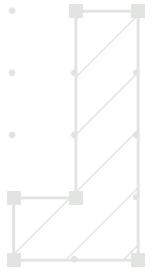



RIDE-ON POWER TROWEL

HUSQVARNA CRT 36

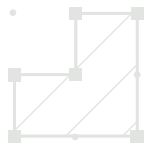



CONCRETE BUGGIES

CLASS	MODEL	TOWABLE	TUB VOLUME	MAX LOAD CAPACITY	DIMENSIONS
Tracked Concrete Buggy, Gas	TORO MBTX 2500S	No	16' 3"	2,500 lbs	Platform Down: 9' 1" x 2' 11.5" x 4' 3.25" Platform Up: 7' 10" x 2' 11.5" x 4' 3.25"
Wheeled Concrete Buggy, Gas	TORO MB-1600	-	16' 3"	Double Wheel: 2,500 lbs Single Wheel: 1,875 lbs	Double Wheel: 8' 9.5" x 3' 10" x 3' 9" Single Wheel: 8' 9.5" x 2' 9.7" x 3' 9"



MULTIQUIP
MC94SE



MULTIQUIP
MC12PH



MULTIQUIP
WM90PH8

CONCRETE MIXERS AND PLACEMENT

CLASS	MODEL	TOWABLE	DRUM CAPACITY	OPERATING WEIGHT
Concrete Mixer 9 CF Steel Drum, Electric	MULTIQUIP MC94SE ⚡	Yes	9 cu. ft.	800 lbs
Concrete Mixer 9 CF Steel Drum, Gas	MULTIQUIP MC94SH8	Yes	9 cu. ft.	800 lbs
Mortar Mixer 12 CF Poly Drum, Gas	MULTIQUIP MC12PH	Yes	12 cu. ft.	1,000 lbs
Mortar Mixer 9 CF Poly Drum, Electric	MULTIQUIP WM90PE ⚡	Yes	9 cu. ft.	770 lbs
Mortar Mixer 9 CF Poly Drum, Gas	MULTIQUIP WM90PH8	Yes	9 cu. ft.	785 lbs
Concrete Placement Bucket, 3 yd	GAR-BRO 420R	No	20.25 cu. ft.	330 lbs

⚡ * Electric Powered Assets



HUSQVARNA
CRT 36



WACKER NEUSON
M1500



MULTIQUIP
MB25A

CONCRETE PREP AND FINISHING

CLASS	MODEL	TROWELING DIAMETER	HORSEPOWER	VIBRATIONS	VOLTAGE
36" Ride-On Power Trowel, Gas	HUSQVARNA CRT 36	36"	22.9 hp	-	-
36" Walk-Behind Power Trowel, Gas	HUSQVARNA CT 36	36"	4.8 hp	-	-
48" Ride-On Power Trowel, Gas	HUSQVARNA CRT 48	48"	57 hp	-	-
48" Walk-Behind Power Trowel, Gas	HUSQVARNA CT 48	48"	7.9 hp	-	-
60" Ride-On Power Trowel, Gas	HUSQVARNA CRT 60X	60"	74 hp	-	-
Concrete Vibrator 1-2 hp	WACKER NEUSON M1500	-	2 hp	14,000 RPM	120 V
Concrete Vibrator 3 hp	WACKER NEUSON M2500	-	2.5 hp	16,000 RPM	120 V
Rebar Bender 1" Electric Bench	MULTIQUIP MB25A	-	-	-	115 V



HUSQVARNA
K770



HUSQVARNA
FS3500 G



HILTI
DD250

CUTTING AND CORING

CLASS	MODEL		HORSEPOWER	CUTTING DEPTH
14" Hand-Held Cut Off Saw, Gas	HUSQVARNA K770		5 hp	5"
20" Walk-Behind Saw, Gas	HUSQVARNA FS520		20.8 hp	7.7"
24" Walk-Behind Saw, Gas	HUSQVARNA FS524		20.8 hp	9.7"
30" Walk-Behind Saw, Electric	HUSQVARNA FS3500 E 30	⚡	30 hp	12"
30" Walk-Behind Saw, Gas	HUSQVARNA FS3500 G		37 hp	12.25"
36" Walk-Behind Saw, Diesel	HUSQVARNA FS5000 D		47.6 hp	15"
6" Core Drill Kit, Stand and Vacuum	HILTI DD200	⚡	3.2 hp	20"
12" Core Drill Kit, Stand and Vacuum	HILTI DD250	⚡	3.75 hp	20"
Walk-Behind Soff Cut Saw, Gas	HUSQVARNA SOFF-CUT 2000		9.5 hp	1.5"
20" Walk-Behind Saw, Gas	HUSQVARNA FS400		11.7 hp	7.5"

⚡ * Electric Powered Assets

EARTHMOVING

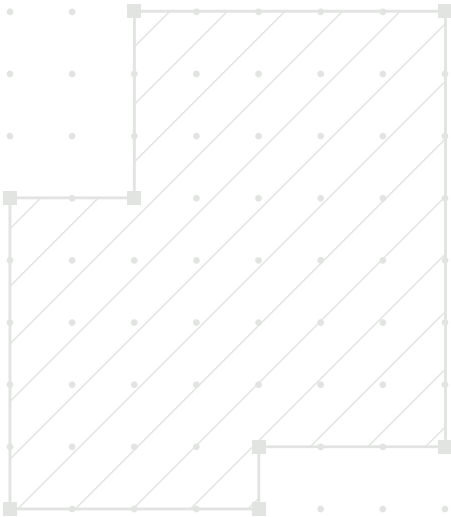
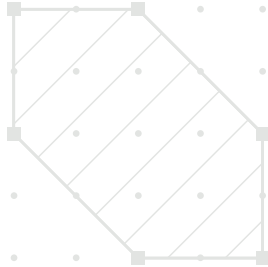



TRACK EXCAVATOR

CASE CX160D



COMPACT TRACK LOADERS

CLASS	MODEL	TYPE	ROC	OPERATING WEIGHT	BREAK OUT FORCE	GROSS POWER
Electric Mini Skid Steer 700–900 lbs ROC	SHERPA 100 ECO	⚡ Ride	700 lbs	1,800 lbs	1,851 lbs	2 hp
Ride-On Mini Skid Steer 800–1,100 lbs ROC	BOBCAT MT100	Ride	1,000 lbs	3,390 lbs	2,760 lbs	24.8 hp
Track Skid Loader 1,700–1,900 lbs ROC	TAKEUCHI TL6	Ride	1,841 lbs	Canopy: 7,485 lbs Cab: 7,780 lbs	Bucket: 5,930 lbs Lift Arm: 4,860 lbs	65.2 hp
Track Skid Loader 2,000–2,300 lbs ROC	KUBOTA SVL75	Ride	2,300 lbs	9,039 lbs	Bucket: 6,204 lbs Lift Arm: 4,766 lbs	74 hp
Track Skid Loader 2,500–2,800 lbs ROC	BOBCAT T62	Ride	2,150 lbs	8,612 lbs	7,465 lbs	68 hp
Track Skid Loader 3,100–3,400 lbs ROC	BOBCAT T740	Ride	3,100 lbs	10,127 lbs	Lift: 6,994 lbs Tilt: 6,496 lbs	74 hp
Track Skid Loader 3,600–4,000 lbs ROC	TAKEUCHI TL12V2	Ride	4,107 lbs	Canopy: 12,860 lbs Cab: 13,190 lbs	Bucket: 7,874 lbs Lift Arm: 7,109 lbs	111.3 hp
Track Skid Loader 2,500–2,800 lbs ROC	TAKEUCHI TL10V2-CR	Ride	2,522 lbs	Canopy: 9,950 lbs Cab: 10,270 lbs	6,520 lbs	74.3 hp



MAX SPEED	GROUND PRESSURE	AUXILIARY STANDARD-FLOW	TIPPING LOAD	REACH @ MAX HEIGHT
4 mph	4.3 psi	5 gpm	484–771 lbs	8' 4"
4.1 mph	5.25 psi	12 gpm	2,898 lbs	23"
6.2 mph	5.1 psi	17.8 gpm	5,269 lbs	9' 6.4"
7.1 mph	5.6 psi	17.4 gpm	6,570 lbs	41.7"
7.2 mph	5.64 psi	17.6 gpm	6,143 lbs	23"
6.6 mph	4.2 psi	23 gpm	8,857 lbs	2' 9"
7.3 mph	4.8 psi	23.2 gpm	11,737 lbs	4' 8"
7 mph	5.1 psi	18.8 gpm	7,205 lbs	9' 5"

⚡ * Electric Powered Assets



JOHN DEERE
450K



CASE
750M



JOHN DEERE
650K

TRACK DOZERS

CLASS	MODEL	TYPE	BLADE DEPTH-BELOW GROUND	OPERATING WEIGHT
Track Dozer 16,000–18,000 lbs, 65–80 HP	JOHN DEERE 450K	Ride	20.8"	38,603 lbs
Track Dozer 20,000 lbs, 85–95 HP	JOHN DEERE 550K	Ride	20.6"	19,290 lbs
Track Dozer 20,000 lbs, 85–95 HP	CASE 750M	Ride	22.84"	20,666.20 lbs
Track Dozer 22,000 lbs, 100–115 HP	JOHN DEERE 650K	Ride	19.7"	49,258 lbs
Track Dozer 30,000–32,000 lbs, 125–135 HP	JOHN DEERE 700L	Ride	21"	31,943 lbs
Track Dozer 35,000–40,000 lbs, 155–165 HP	JOHN DEERE 750L	Ride	23.4"	38,330 lbs
Track Dozer 45,000–55,000 lbs, 215–235 HP	CASE 2050M	Ride	21.5"	45,414 lbs



MAX SPEED	GROUND PRESSURE	GROSS POWER
6 mph	6.4 psi	80.5 hp
6 mph	5.79 psi	92 hp
5.2 mph	5.36 psi	92 hp
6 mph	6.4 psi	104.6 hp
5.5 mph	4.66 psi	135 hp
6 mph	6.93 psi	175 hp
6.1 mph	7.33 psi	214 hp



BACKHOE AND SKIP LOADERS

CLASS	MODEL	TYPE
Skip Loader 60–85 HP	JOHN DEERE 210G	Ride
Backhoe Loader 68–74 HP, Standard Stick	CASE 580N-EP	Ride
Backhoe Loader 68–74 HP, Extendable Stick	CASE 580N-EP EXT	Ride
Backhoe Loader 68–74 HP, Standard Stick	JOHN DEERE 310LEP	Ride
Backhoe Loader 68–74 HP, Extendable Stick	JOHN DEERE 310LEP - Extendable Stick	Ride
Backhoe Loader 110–115 HP, Standard Stick	JOHN DEERE 410L	Ride
Backhoe Loader 110–115 HP, Extendable Stick	JOHN DEERE 410L EXT	Ride
Backhoe Loader 145–150 HP, Extendable Stick	JOHN DEERE 710L	Ride



MAX DIG DEPTH	OPERATING WEIGHT	GROSS POWER
21' 11"	49,139 lbs	159 hp
11' 7"	15,995 lbs	74 hp
18' 6"	15,995 lbs	74 hp
14'	14,430 lbs	72 hp
17' 9"	15,880 lbs	72 hp
15' 9"	17,547 lbs	102 hp
19' 7"	19,224 lbs	102 hp
17' 3"	25,589.10 lbs	148 hp



MINI EXCAVATORS

CLASS	MODEL		TYPE	MAX DIG DEPTH
Mini Excavator 2,500–4,000 lbs	BOBCAT E10		Ride	6'
Mini Excavator 2,500–4,000 lbs	TAKEUCHI TB210R		Ride	5' 9.1"
Mini Excavator 4,000–4,900 lbs, Electric	JCB 19C-1E	⚡	Ride	7' 11.4"
Mini Excavator 5,000–6,500 lbs	BOBCAT E26		Ride	8' 6"
Mini Excavator 5,000–6,500 lbs	SANY SY26U		Ride	9' 3"
Mini Excavator 7,000–9,000 lbs	SANY SY35U		Ride	10' 2"
Mini Excavator 7,000–9,000 lbs	BOBCAT E35		Ride	10' 1.2"
Mini Excavator 10,000–14,000 lbs	BOBCAT E50		Ride	11' 7.2"
Mini Excavator 15,000–19,000 lbs	TAKEUCHI TB290		Ride	15'



MAX DIGGING FORCE	MAX REACH	OPERATING WEIGHT	HORSEPOWER
1,865 lbs	12' 3"	2,593 lbs	10.2 hp
1,439 lbs	13'	2,535 lbs	11.7 hp
3,637 lbs	13' 3"	3,855.90 lbs	15.7 hp
4,500 lbs	12' 9"	5,666 lbs	24.8 hp
5,800 lbs	13' 1"	6,085 lbs	19.6 hp
8,500 lbs	15' 1"	8,499 lbs	24.4 hp
6,125 lbs	15' 8"	7,659 lbs	25 hp
8,000 lbs	18' 2"	10,677 lbs	49.8 hp
13,500 lbs	21' 4"	18,630 lbs	69.2 hp

⚡ * Electric Powered Assets



HITACHI
ZX135US-6



LINK-BELT
145X4DZ



CASE
CX160D

TRACK EXCAVATORS

CLASS	MODEL	TYPE	MAX DIG DEPTH
Track Excavator 25,000 – 35,000 lbs	HITACHI ZX135US-6	Ride	19' 7.4"
Track Excavator 25,000 – 35,000 lbs, Reduced Tailswing	LINK-BELT 145X4DZ	Ride	18' 1"
Track Excavator 25,000 – 35,000 lbs	SANY SY135C	Ride	18' 1"
Track Excavator 38,000 – 39,000 lbs	CASE CX160D	Ride	19' 1.3"
Track Excavator 45,000 – 55,000 lbs	HITACHI ZX210LC-6	Ride	21' 11"
Track Excavator 45,000 – 55,000 lbs	SANY SY215C	Ride	21' 8"
Track Excavator 56,000 – 65,000 lbs	SANY SY265	Ride	22'
Track Excavator 56,000 – 65,000 lbs, Long Reach	SANY SY265LR	Ride	43' 8"
Track Excavator 56,000 – 65,000 lbs, Reduced Tailswing	LINK-BELT 250X4LC	Ride	47' 9"
Track Excavator 66,000 – 75,000 lbs	CASE CX300D	Ride	23' 3.6"
Track Excavator 80,000 – 85,000 lbs	SANY SY365	Ride	23' 11"
Track Excavator 110,000 – 120,000 lbs	HITACHI ZX470LC-6	Ride	23' 10.7"



HITACHI
ZX210LC-6



LINK-BELT
250X4LC



CASE
CX300D

MAX REACH	OPERATING WEIGHT	HORSEPOWER
29' .8"	30,644.3 lbs	101 hp
27' 2"	32,000 lbs	102 hp
27' 2"	32,783 lbs	103.9 hp
26' 1"	38,360.5 lbs	112 hp
32' 7"	50,265 lbs	163.6 hp
33' 10"	51,919 lbs	163.6 hp
33' 7"	59,525 lbs	194.4 hp
57' 9"	69,446 lbs	190.4 hp
59' 9"	63,600 lbs	177 hp
35'	66,478.2 lbs	154 hp
36' 5"	80,910 lbs	275 hp
34' 2.2"	110,804 lbs	362 hp



BOBCAT
S70



JOHN DEERE
318G

WHEELED SKID LOADERS

CLASS	MODEL	TYPE
Wheeled Skid Loader 700–1,400 lbs ROC	BOBCAT S70	Ride
Wheeled Skid Loader 1,500–2,200 lbs ROC	JOHN DEERE 318G	Ride
Wheeled Skid Loader 2,300–2,900 lbs ROC	JOHN DEERE 324G	Ride
Wheeled Skid Loader 3,000–4,000 lbs ROC	JOHN DEERE 330G	Ride



OPERATING WEIGHT	FUEL CAPACITY	HORSEPOWER
2,795.5 lbs	6.5 gal	23.5 hp
6,542 lbs	19 gal	61 hp
7,700 lbs	21 gal	74 hp
9,900 lbs	25.5 gal	91.2 hp



WHEEL LOADERS

CLASS	MODEL	TYPE	OPERATING WEIGHT
Wheel Loader 70–105 HP, 1.5 cu. yd	CASE 321F	Ride	13,302.7 lbs
Wheel Loader 105–135 HP, 2 cu. yd	CASE 521G	Ride	24,290.6 lbs
Wheel Loader 150–155 HP, 3 cu. yd	JOHN DEERE 524P	Ride	28,931 lbs
Wheel Loader 165–175 HP, 3 cu. yd	HITACHI ZW180-6	Ride	32,777–33,220 lbs
Wheel Loader 165–175 HP, 3 cu. yd	JOHN DEERE 544P	Ride	30,520 lbs
Wheel Loader 190–195 HP, 4 cu. yd	JOHN DEERE 624L	Ride	34,715 lbs
Wheel Loader 230–255 HP, 4 cu. yd	JOHN DEERE 644L	Ride	41,246 lbs



REACH AT MAX LIFT AND DUMP	BREAKOUT FORCE	HORSEPOWER
3' 3.6"	11,000 lbs	74 hp
4' 8.9"	20,934 lbs	142 hp
4' 9"	24,406 lbs	152 hp
3' 8"	26,530 lbs	173 hp
4' 11"	29,026 lbs	166 hp
5' 2"	29,994 lbs	192 hp
5' 3"	34,334 lbs	249 hp



MOTOR GRADERS

CLASS	MODEL	TYPE	OPERATING WEIGHT	MOLDBOARD WIDTH	HORSEPOWER
Motor Grader 260 HP, 4WD, 14' Moldboard	SANY SMG200C	Ride	45,107 lbs	14'	253 hp

FORKLIFTS AND MATERIAL HANDLING

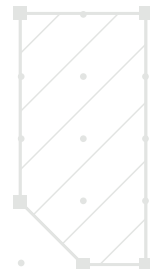
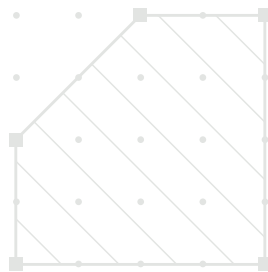

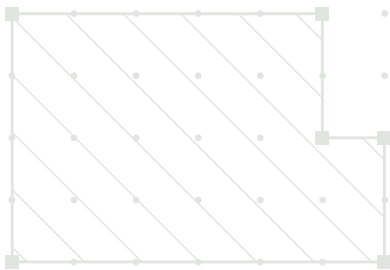
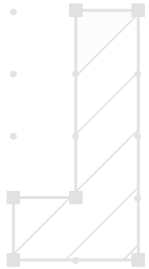



TELEHANDLERS

CLASS	MODEL	MAX LIFT HEIGHT	HORIZONTAL REACH	MAX LIFT CAPACITY
Telehandler 2,500–4,500 lbs, 12'–14' Reach	SKYTRAK 3013	13'	7'	2,700 lbs
Telehandler 5,000–5,500 lbs, 18'–20' Reach	GENIE GTH-5519 ⓘ	18' 10"	11' 3"	5,500 lbs
Telehandler 5,000–5,500 lbs, 18'–20' Reach	JCB 505-20TC	20'	11' 6"	5,500 lbs
Telehandler 6,000–7,000 lbs, 34'–44' Reach	MANITOU MTA 6034	34'	23' 3"	6,062.72 lbs
Telehandler 6,000–7,000 lbs, 34'–44' Reach	GENIE GTH-636 ⓘ	36'	21' 11"	6,000 lbs
Telehandler 8,000–9,000 lbs, 40'–44' Reach	JCB 509-42 ⓘ	42'	28'	9,000 lbs
Telehandler 8,000–9,000 lbs, 40'–44' Reach	GENIE GTH-844	43' 10"	28'	8,000 lbs
Telehandler 10,000 lbs, 54'–56' Reach	MANITOU MTA 10055 ⓘ	55'	41' 2"	10,031.04 lbs
Telehandler 10,000 lbs, 54'–56' Reach	JCB 510-56	56'	42'	10,000 lbs
Telehandler 12,000 lbs, 54'–56' Reach	JCB 512-56	56'	42'	12,000 lbs
Telehandler 14,000–15,000 lbs, 44'–56' Reach	JCB 514-56	56'	42'	14,000 lbs
Telehandler 16,000–17,000 lbs, 32'–44' Reach	JLG 1732	31' 8"	18' 6"	16,755 lbs
Telehandler 20,000–29,000 lbs, 32'–44' Reach	MAGNI 10.10 ⓘ	31' 2"	16' 6"	22,046 lbs
Telehandler 30,000–39,000 lbs, 32'–44' Reach	MAGNI 16.10 ⓘ	31' 2"	16' 8"	35,273 lbs
High Reach Telehandler 8,500 lbs, 66' Reach	JCB 508-66	65' 7"	52'	3,300 lbs
High Reach Telehandler 10,000 lbs, 75' Reach	JLG 1075	75'	60'	10,000 lbs
High Reach Telehandler 12,000 lbs, 80' Reach	MAGNI 12.80	78' 5"	62' 6.4"	12,100 lbs
Rotator 10,000–11,000 lbs	MAGNI 5.25	82'	62' 4"	11,000 lbs
Rotator 13,000–14,000 lbs	MAGNI 6.30 ⓘ	97' 9"	85' 4"	13,200 lbs

ⓘ * More Info on pg. 60



CARRY DECK CRANES AND ROTATING TELEHANDLERS

CLASS	MODEL	HORIZONTAL REACH	MAX LIFT CAPACITY	SHEAVE HEIGHT
Carry Deck Crane 18,000 lbs, Dual Fuel	BRODERSON IC80 Dual Fuel ⓘ	40'	18,000 lbs	46' 8"
Carry Deck Crane 18,000 lbs, Diesel	BRODERSON IC80 Diesel	40'	18,000 lbs	46' 8"
Carry Deck Crane 30,000 lbs, Dual Fuel	BRODERSON IC200 Dual Fuel ⓘ	66'	30,000 lbs	73' 8" (with boom extension)
Carry Deck Crane 30,000 lbs, Diesel	BRODERSON IC200 Diesel	66'	30,000 lbs	73' 8" (with boom extension)
Carry Deck Crane 36,000 lbs, Dual Fuel	BRODERSON IC250 Dual Fuel ⓘ	70' 1"	36,000 lbs	79' 6" (with boom extension)
Carry Deck Crane 36,000 lbs, Diesel	BRODERSON IC250 Diesel	70' 1"	36,000 lbs	79' 6" (with boom extension)



INDUSTRIAL FORKLIFTS - INTERNAL COMBUSTION

CLASS	MODEL	MAX LIFT HEIGHT	MAX LIFT CAPACITY	LENGTH TO FORK FACE	TURNING RADIUS
Industrial Forklift 5,000 lbs, Diesel	HYUNDAI 25D-9	6' 10.7"	5,000 lbs	8' 7"	7' 8"
Industrial Forklift 5,000 lbs, Dual Fuel	KOMATSU FG25T-16	10' 8"	5,000 lbs	8' 6.5"	7' 4.2"
Industrial Forklift 5,000 lbs, Propane	TOYOTA 8FGU25 LP	11' 11.5"	4,960.41 lbs	8' 8"	7' 3.5"
Industrial Forklift 6,000 lbs, Diesel	HYUNDAI 30D-9	10' 10"	6,000 lbs	8' 9"	7' 10.9"
Industrial Forklift 6,000 lbs, Propane	TOYOTA 8FGU30 LP	10' 11.8"	6,000 lbs	9' 1.6"	7' 8.5"
Industrial Forklift 8,000 lbs, Diesel	CLARK C40	10' 9.8"	8,000 lbs	9' 11.8"	9' 3"
Industrial Forklift 8,000 lbs, Dual Fuel	Unicarrier MJ1F4A35DV	10' 9.8"	7,000 lbs	10' 8"	8' 11"
Industrial Forklift 10,000 lbs, Diesel	CLARK C50S	10' 9.8"	11,023 lbs	10' 7.2"	9' 11.4"
Industrial Forklift 28,000 lbs – 24" LC, Diesel	SANY SCP130	12' 4"	28,600 lbs	14' 11"	13' 7.4"
Industrial Forklift 33,000 lbs – 36,000 lbs, Diesel	SANY SCP160	13' 1.5"	35,000 lbs	18' 8.5"	16' 8.8"
Rough Terrain Forklift 6,000 lbs, Diesel	CASE 586H	15'	6,000 lbs	16'	10' 2.5"
Rough Terrain Forklift 8,000 lbs, Diesel	CASE 588H	15'	16,102 lbs	23' 8"	12' 10.6"



ELECTRIC AND MANUAL MATERIAL HANDLING

CLASS	MODEL	MAX LIFT HEIGHT	MAX LIFT CAPACITY	LOAD CENTER	TURNING RADIUS
Pallet Jack 4,500 lbs, Manual	TOYOTA HPT28U	7.7"	5,500 lbs	2'	4' 9"
Pallet Jack 4,500 lbs, Electric	HYSTER W45ZHD ⚡	8.4"	4,500 lbs	2' 4"	4' 4"
Pallet Stacker, Electric	TOYOTA 8BWS10 ⚡	11' 10.9"	2,000 lbs	2' 9"	4' 8.4"
Material Lift, 16'	GENIE SLC-18	18' 6"	650 lbs	1' 2"	4' 3"
Material Lift, 20'–24'	GENIE SLC-24	24'	650 lbs	1' 2"	5' 2"
Industrial Forklift, Stand-On, 3,000–4,000 lbs, Electric	TOYOTA 7BRU18 ⚡	22' 6"	3,500 lbs	2'	6' 8"
Industrial Forklift 5,000 lbs, Electric	CLARK TMX25-AC ⚡	6' 10.9"	5,000 lbs	2'	6'
Electric Hoist Chain	HARRINGTON L5LB015-20	20'	3,000 lbs	-	-

⚡ * Electric Powered Assets



RANGE OF MOTION & LIFT PERFORMANCE

Telehandlers, Rotators and Carry Deck Cranes

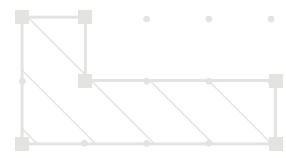

Telehandler
GENIE GTH-5519

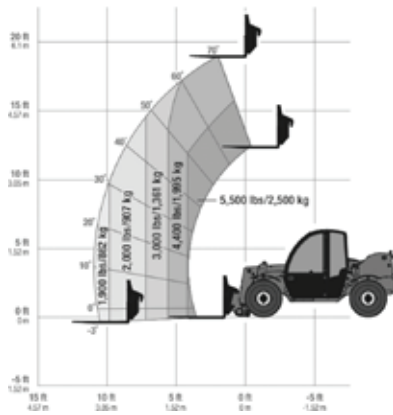

Telehandler
GENIE GTH-636

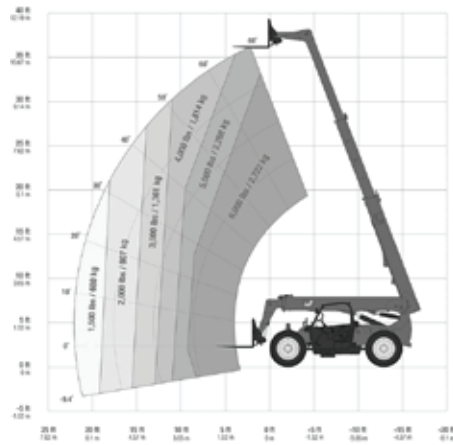

Telehandler
JCB 509-42

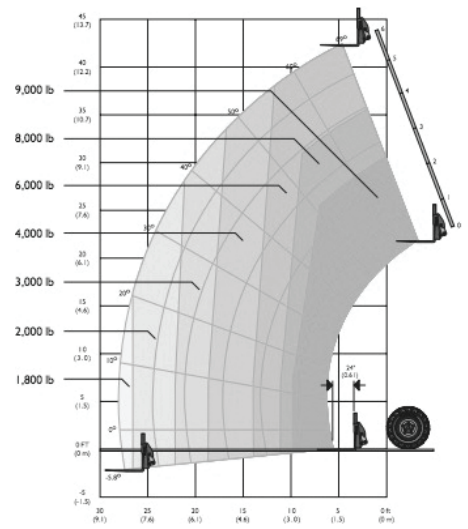

Telehandler
MANITOU MTA 10055

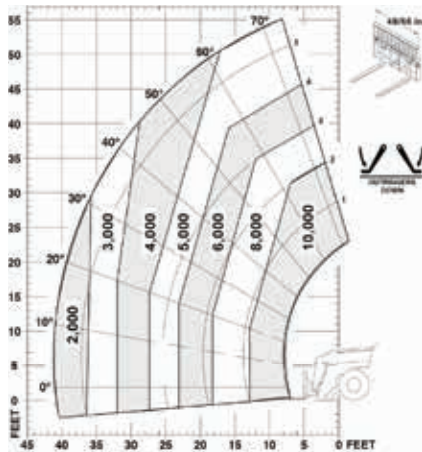

Telehandler
MAGNI 10.10

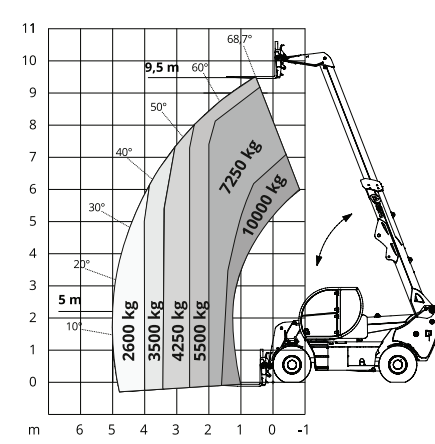

Telehandler
MAGNI 16.10

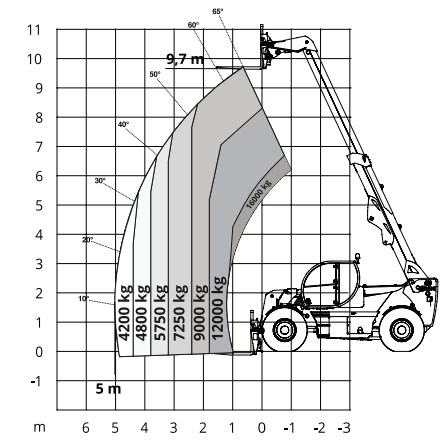



Rotator
MAGNI 6.30

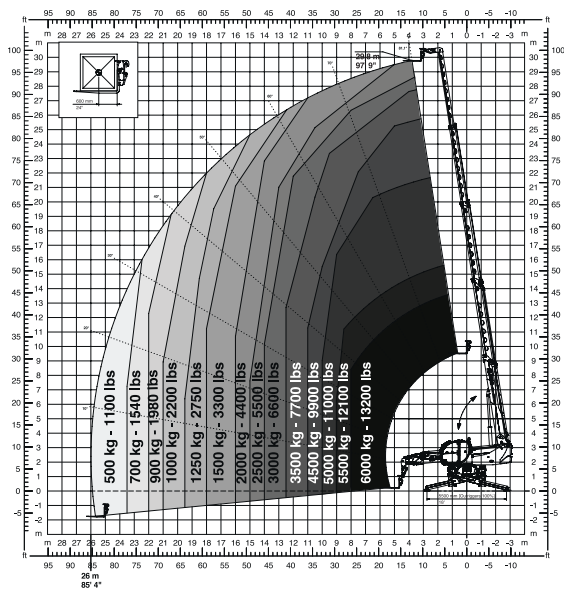

Carry Deck Crane
BRODERSON IC80

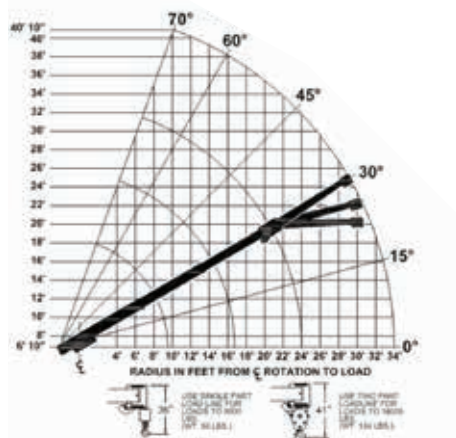

Carry Deck Crane
BRODERSON IC200

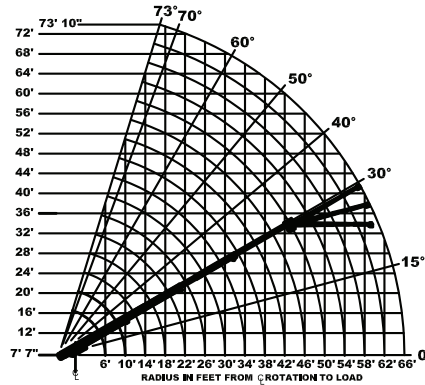

Carry Deck Crane
BRODERSON IC250

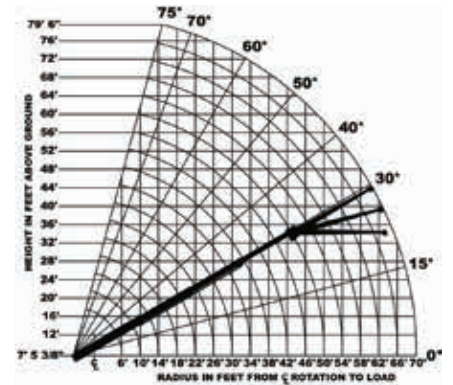

LIGHTING AND SECURITY

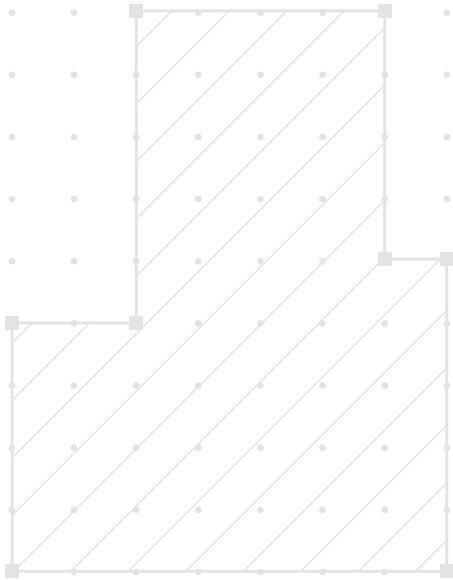
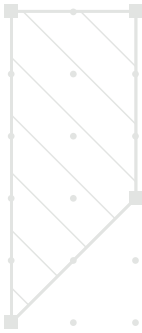



TOWABLE LIGHT PLANT

WACKER NEUSON LTW20





WOBBLE LIGHT
101-111104



LIND
LE360LED-TR



MULTIQUIP
GB8LED

GENERAL CONSTRUCTION LIGHTING

CLASS	MODEL		LUMENS	LIGHTING RANGE
Wobble Light 400W, Metal Halide	WOBBLE LIGHT 101-111104	⚡	40,000 lm	110'
Light Stand, LED	LIND LE360LED-TR	⚡	14,300 lm	50'
Light String Daisy Chain, LED	LIND LELED360S-10P10C	⚡	2,400 lm	15'
Light String 8' Head, Explosion Proof	LIND TLS-80XPLEDRE-LV	⚡	800 lm per bulb	50' of cord, followed by 8 LED lights spaced 10' apart
Light String 50'	SOUTHWIRE COMPANY 121050	⚡	14 watts per socket	spaced every 5' or 10'
Light Stand Balloon, LED	MULTIQUIP GB8LED	⚡	110,000 lm	34'

⚡ * Electric Powered Assets



SECURITY SYSTEMS				
CLASS	MODEL	MAST HEIGHT	IR ILLUMINATION	WEIGHT
4 Camera Security Plant	WANCO WCTS-520	19' 6"	160'	1,550 lbs



LIND
LE980LED-T4B



WANCO
WLTSSM4A750

SOLAR LIGHT PLANTS AND LIGHT CARTS

CLASS	MODEL	LUMENS	WEIGHT	HEIGHT
Light Cart, Electric	LIND EQUIPMENT LE980LED-T4B ⚡	120,000 lm total	380 lbs	6' 10"
Solar Light Tower, 750W	WANCO WLTSSM4A750 ⚡	34,860 lm total	1,550 lbs	Travel: 9' Deployed: 19' 8"

⚡ * Electric Powered Assets



TOWABLE LIGHT PLANTS

CLASS	MODEL	LUMENS	RUN TIME	FUEL TANK	WEIGHT
3kW Light Plant, LED	ALLMAND NLV3GR	204,488 lm	360 hrs	63 gal	1,155 lbs
6kW Light Plant, LED	WACKER NEUSON LTV6K-LED	154,000 lm	95 hrs	45.8 gal	1,790 lbs
6kW Light Plant, Metal Halide	WACKER NEUSON LTV6L-MH	154,000 lm	98.8 hrs	45.78 gal	1,435 lbs
8kW Light Plant, LED	ALLMAND NIGHT-LITE PRO II	154,000 lm	48.4 hrs	30.12 gal	1,950 lbs
8kW Light Plant, Metal Halide	ALLMAND NIGHT-LITE	154,000 lm	72.6 hrs	44.98 gal	1,885 lbs
20kW Light Plant, LED	WACKER NEUSON LTW20Z1	180,000 lm	34.8 hrs	57 gal	3,450 lbs

SAFETY, TESTING AND COMMUNICATION



DIGITAL RADIO

MOTOROLA XPR3300E





MOTOROLA
XPR3300E



RIDGID
63613



WIDDER
11340

SAFETY, TESTING AND COMMUNICATION

CLASS	MODEL	
Gas Monitor H2S	BW TECH BWC2-H	⚡
Gas Detector Multi 4 Gas	MSA ALTAIR 4X	⚡
Radio Digital Intrinsically Safe	MOTOROLA XPR3300E	⚡
Radio Digital Intrinsically Safe	MOTOROLA XPR7550	⚡
Confined Space Entry Kit 60'	FALLTECH 7509	
Fall Protection Lanyard Extension 18"	GENERAL WORKS PRODUCTS LE18134	
Pipe Camera 200' w/Monitor	RIDGID 63613/CS65X	⚡
Pipe Jeep Holiday Detector	SPY 785	⚡
Pump Hydrostatic Test Air 10,000 PSI, High-Flow	WIDDER 11340	
Skidmore Torque Tension Calibrator	SKIDMORE MODEL H	⚡

⚡ * Electric Powered Assets

SURFACE PREPARATION AND CLEANING



PRESSURE WASHER

SIMPSON 61023



PRESSURE WASHERS

CLASS	MODEL
Pressure Washer 2,700 PSI, 2.3 GPM, Cold	SIMPSON 61023
Pressure Washer 4,000 PSI, 4 GPM, Hot	SIMPSON 65106
Pressure Washer 3,500 PSI, 2.5 GPM, Hot	SIMPSON 65123
Towable Pressure Washer 4,000 PSI, 4 GPM, 200 Gal, Hot	SIMPSON 95005
Towable Pressure Washer 3,500 PSI, 5.5 GPM, 525 Gal, Hot	SIMPSON 95122



KARCHER
BD70 W BP



KARCHER
B 75 R BP



TENNANT
S30

SWEEPERS AND SCRUBBERS

CLASS	MODEL		TYPE	SWEEP WIDTH	BRUSH SPEED
Walk-Behind Floor Scrubber 28", Battery	KARCHER BD70 W BP	⚡	Walk-Behind	28"	180 rpm
Walk-Behind Floor Scrubber 36", Battery	TENNANT T500E	⚡	Walk-Behind	26"	220 rpm
Ride-On Floor Scrubber 40", Battery	KARCHER B 75 R BP	⚡	Ride-On	30"	180-1,200 rpm
Ride-On Floor Scrubber 40", LPG	TENNANT M20		Ride-On	40"	480 rpm
Ride-On Floor Sweeper 50", Battery	TENNANT S20E	⚡	Ride-On	50"	-
Ride-On Floor Sweeper 50", LPG	TENNANT S20		Ride-On	50"	-
Ride-On Floor Sweeper 60", Battery	TENNANT S30	⚡	Ride-On	62.5"	-
Walk-Behind Floor Sweeper 30", Battery	TENNANT S10	⚡	Walk-Behind	34"	550 rpm

⚡ * Electric Powered Assets



BROCE
BW260



LAYMOR
SM450-ST



BROCE
RCT350

JOBSITE SWEEPERS

CLASS	MODEL	SWEEPING WIDTH	HORSEPOWER	BRUSH SPEED
3 Wheel Sweeper, Mid-Mount Broom, Diesel	BROCE BW260	8'	24 hp	192 rpm
4 Wheel Sweeper, Front-Mount Broom, Diesel	SB MANUFACTURING SM74J	8'	74 hp	-
4 Wheel Sweeper, Mid-Mount Broom, Diesel	LAYMOR SM450	8'	74 hp	210 rpm
4 Wheel Sweeper, Mid-Mount Broom, Diesel	BROCE RCT350	8'	74 hp	192 rpm

VEHICLES AND TRAILERS



WATER TRUCK

FORD F750

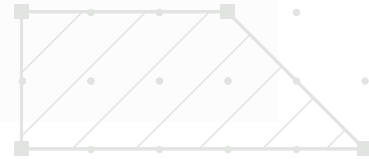



WATER TRUCKS AND DUMP TRUCKS

CLASS	MODEL	PASSENGERS	BED LENGTH
Water Truck 2,000 Gal, Diesel	FORD F750, DIESEL	2	9' 6"
Water Truck 2,000 Gal, Gas	FORD F750, GAS	5	9' 6"
Water Truck 2,000–2,500 Gal, Diesel	FREIGHTLINER M2106 2K WATER TRUCK, DIESEL	2	8' 10"
Water Truck 4,000 Gal, Diesel	INTERNATIONAL HV607	2	8' 11"
Water Truck 4,000–4,500 Gal, Diesel	FREIGHTLINER M2106 4K WATER TRUCK, DIESEL	2	8' 10"
Dump Truck 5/6yd, Diesel	FREIGHTLINER M102, DIESEL	2	8' 10"
Dump Truck 5/6yd, Gas	FREIGHTLINER M102, GAS	2	8' 10"
Dump Truck 10/12yd, Diesel	FREIGHTLINER M102, DIESEL	2	8' 10"
Single Axle Dump Truck, 5/6yd, Diesel	FREIGHTLINER M2106 5/6 yd. DUMP TRUCK, DIESEL	2	8' 10"
Crash Attenuator Truck, Gas	FORD F650, GAS	2	9' 6"
Utility Vehicle 4–6 Passenger, Diesel	KUBOTA RTV-X1140W-H	4–6	2' 2"



RENTAL TRAILERS				
CLASS	MODEL	MEASUREMENTS	WEIGHT	DOLLY COUPLER
Rental Equipment Trailer, 4' x 6', 3,000 lbs Axle	BARRETO E4X6TBT-3K-ES	L x W x H: 10' 5/8" x 5' 3/16" x 20"	Empty Weight: 500 lbs Gross Weight: 2,200 lbs	2" Ball
Rental Equipment Trailer, 10,000 – 14,000 lbs	BIGTEX 14ET-18BK-KR	18' Floor Length	2,540 – 2,940 lbs	2-5/16" Adjustable
Dump trailer, 7' x 14'	STEELPOINT D714E	⚡ 14' Bed Length	4,390 lbs	2-5/16" Ball
16' Kneeling Axle Trailer	JLG TRIPLE L	16' Deck Length	3,150 lbs	2.3" Ball
Water Trailer, 500 Gal	MULTIQUIP WT5	12' Length	1,428 lbs	2-5/16" Ball

⚡ * Electric Powered Assets



RENTAL VEHICLES

CLASS	MODEL	PASSENGERS	BED LENGTH
1/2 Ton Rental Truck	RAM 1500	5	5' 7" x 5' 6"
3/4 Ton Rental Truck	RAM 2500	6	6' 4" x 5' 6"
12–15 Passenger Van	FORD TRANSIT	15	-
Electric Sedan	TESLA MODEL 3 ⚡	5	-
Electric SUV	TESLA MODEL Y ⚡	5	-

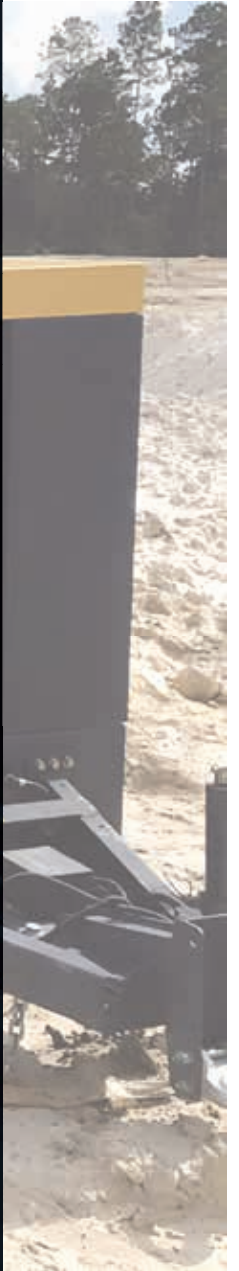



 **ADVANCED SOLUTIONS**

Climate Control

Event and Site Services

Fluid Solutions

Power Solutions

CLIMATE CONTROL

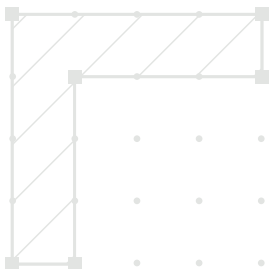
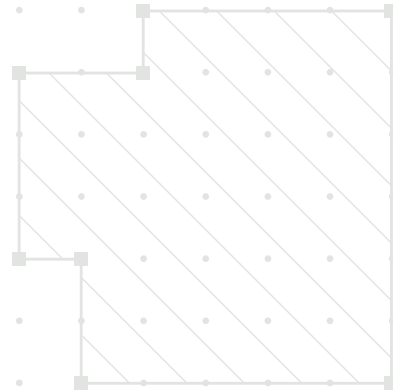

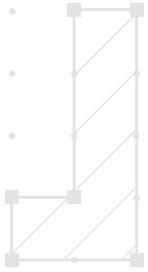
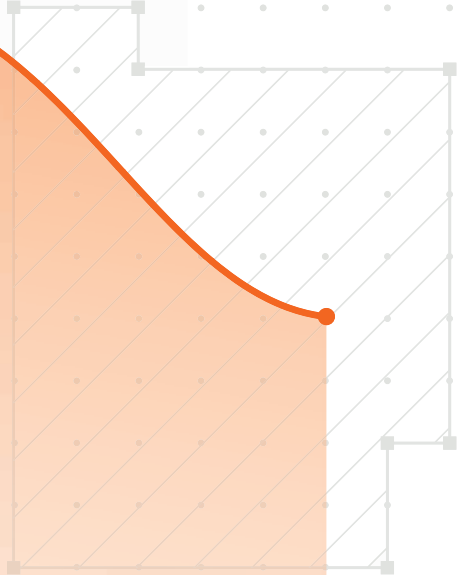
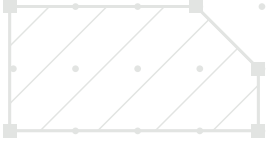

PORTABLE AIR CONDITIONING

KWIKOOL KPAC-1411-2



KWIKOOL
KPAC-1411-2



OCEANAIRE
OWC1811QC



KWIKOOL
KP012-23

PORTABLE AIR CONDITIONING

CLASS	MODEL	
1 Ton AC/Dehu Unit	KWIKOOL KPAC-1411-2	⚡
1.3 Ton AC/Water Cooled Unit	OCEANAIRE OWC1811QC	⚡
1.5 Ton AC/Dehu Unit	KWIKOOL KPAC-1811-2	⚡
1.5 Ton AC/Dehu/Heat Pump Unit	KWIKOOL KPHP-2211	⚡
2 Ton AC/Dehu Unit	KWIKOOL KPAC-2421-1	⚡
3.5 Ton AC/Dehu Unit, 208/230V, 1P	KWIKOOL KPHP-2211	⚡
5 Ton AC/Dehu Unit, 230V, 1P	KIB6021-2	⚡
5 Ton AC/Dehu Unit, 230V, 3P	KIB6023-2	⚡
5 Ton indoor/outdoor Air Conditioner, 208V, 1P	KWIKOOL KP05-21	⚡
5 Ton indoor/outdoor Air Conditioner, 230V, 3P	KWIKOOL KP05-23	⚡
5 Ton indoor/outdoor Air Conditioner, 460V, 3P	KWIKOOL KP05-43	⚡
5 Ton AC/Dehu Unit	KWIKOOL KPAC1811-2	⚡
12 Ton DX Air Conditioner w/Heat, 230V, 3P	KWIKOOL KP012-23	⚡
12 Ton DX Air Conditioner w/Heat, 460V	KWIKOOL KP012-43H	⚡

⚡ * Electric Powered Assets



SMARTECH
SACP21A-HS



SMARTECH
SACP25A-HS-XP



SMARTECH
SACP40A-HS-XP

INDUSTRIAL AIR CONDITIONING

CLASS	MODEL	
12 Ton DX Air Conditioner w/Heat	SMARTECH SLIC12R-MS	⚡
20 Ton DX Air Conditioner	SMARTECH SACP21A-HS	⚡
20 Ton DX XP NEMA 7 Air Conditioner	SMARTECH SACP25A-HS-XP	⚡
20 Ton Industrial Unit NEMA 7	CAPS PPKH-40TD-ONNONN-5E5-P2-S1CEUP	⚡
25 Ton DX Air Conditioner w/Heat	AES AES25TDH44TA	⚡
40 Ton DX Air Conditioner	SMARTECH SACP41A-HS	⚡
40 Ton DX XP NEMA 7 Air Conditioner	SMARTECH SACP40A-HS-XP	⚡
40 Ton Industrial Unit NEMA 7	CAPS PPKH-40TD-ONNONN-5B2-P2-S1CEUP	⚡
40 Ton Hybrid Air Conditioner	SMARTECH SHCP47A-HS	⚡
70 Ton Hybrid Air Conditioner	CAPS PPKH-70TD-ONN136KE-5E5-P2-VS1CEUP	⚡
80 Ton DX Air Conditioner	SMARTECH SACP81A-HS	⚡

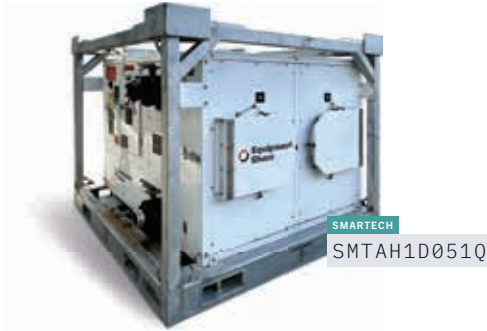

AIR HANDLERS

CLASS	MODEL	
35 Ton Portable Air Handler	SMARTECH SMTAH1D030HQ	⚡
50 Ton Air Handling Unit	SMARTECH SMTAH1D051Q	⚡
75 Ton Air Handling Unit	CAPS PAHH-75TC	⚡
100 Ton Vertical Air Handling Unit	AES AHU-100T	⚡
120 Ton Air Handling Unit	SMARTECH SMTAH1D136Q	⚡
140 Ton Vertical Air Handling Unit	CAPS PAHV-140TC	⚡
200 Ton Air Handling Unit	SMARTECH	⚡

⚡ * Electric Powered Assets



CHILLERS

CLASS	MODEL	
10 Ton Air Cooled Chiller	SMARTTECH STAC10S-R	⚡
30 Ton Air Cooled Chiller	CAPS PCHH-30TC	⚡
60 Ton Air Cooled Chiller	CAPS PCHH-60TC	⚡
70 Ton Air Cooled Chiller	CAPS PCHH-70TC	⚡
100 Ton Air Cooled Chiller	SMARTTECH SCOD101AR4	⚡
230 Ton Air Cooled Chiller	SMARTTECH SCOD230AR4	⚡



PHOENIX
DRYMAX BLE



PHOENIX
R250



SMARTECH
RDDH3000-EH

DEHUMIDIFIERS

CLASS	MODEL	
10-15 GPD LGR Dehumidifier	PHOENIX DRYMAX BLE	⚡
25 GPD LGR Dehumidifier	PHOENIX R250	⚡
385 CFM Desiccant Dehumidifier	DRI-EAZ F533	⚡
2,500 CFM Desiccant Dehumidifier Elec.	SMARTECH RDDH3000-EH	⚡
6,000 CFM Hybrid Dehumidifier	SMARTECH RDDH6000-EH	⚡
7,500 CFM Desiccant Dehumidifier	SMARTECH RDDH7500-EH	⚡

⚡ * Electric Powered Assets



ULINE
H-9347



PORTACOOOL
JETSTREAM 250



POWER BREEZER
PB10-MAX-06-B

FANS

CLASS	MODEL	
12" Ductable Axial Fan	DRI-EAZ F174	⚡
16" Open Air Fan	DRI-EAZ F568	⚡
24" Circulation Fan	PINNACLE MAC-24DCT	⚡
36" Circulation Fan	PINNACLE VKM36-0	⚡
42" Circulation Fan	PINNACLE VKM42-2-0	⚡
48" Circulation Fan	ULINE H-9347	⚡
Carpet Fan, 925 CFM, Low Profile Air Mover	PHOENIX AirMAX BLE	⚡
Carpet Fan, 2,700 CFM, Air Mover	DRI-EAZ F351	⚡
Evaporative Cooling Portacool 24" Fan	PORTACOOOL JETSTREAM 250	⚡
Evaporative Cooling Portacool 36" Fan	BIGASS FANS COLD FRONT 400	⚡
Large Evaporative Cooling Oscillating Misting Fan	POWER BREEZER PB10-MAX-06-B	⚡



ABATEMENT TECH
AG8000PAS



TOTAL ZONE
TZ-4



TITAN
4000

AIR SCRUBBERS

CLASS	MODEL	
10' Hard Sided HEPA Containment Cart	ABATEMENT TECH AG8000PAS	⚡
10' Soft Sided HEPA Containment Cart	ABATEMENT TECH AG3000MCKK	⚡
24,000 sq/ft Ozone Machine	TOTAL ZONE TZ-4	⚡
Hydroxyl Machine	TITAN 4000	⚡
500–600 CFM Negative Air Scrubber	DRI-EAZ HEPA 500	⚡
1000–1200 CFM Negative Air Scrubber	HUSQVARNA A2000	⚡
2000–2400 CFM Negative Air Scrubber	ABATEMENT TECHNOLOGIES BD2KM	⚡

⚡ * Electric Powered Assets



CAMPO
EB150E



FLAGRO
F-150



ALLMAND
MAXI-HEAT 1M BTU

HEATERS

CLASS	MODEL
10kW Electric Heater	FOSTORIA 10kW Electric Heater ⚡
30kW Electric Heater	CAMPO EB30E ⚡
60kW Electric Heater	CAMPO EB60E 480V ⚡
150kW Electric Heater	CAMPO EB150E 480V ⚡
Direct Fired 115k BTU (K/DSL) Heater	Mi-T-M Corporation MH-0075-0M10
Direct Fired 125k BTU (K/DSL) Heater	Mi-T-M Corporation MH-0125-3M1R
Direct Fired 150k BTU (LP) Heater	FLAGRO F-150
Direct Fired 155k BTU (K/DSL) Heater	VELOCI FIRE 155
Direct Fired 200k BTU (K/DSL) Heater	Mi-T-M Corporation MH-0190-0M10
Direct Fired 200–250k BTU (LP,NG,K/DSL) Heater	Mi-T-M Corporation MH-0215-0M10
Direct Fired 300k BTU (K/DSL) Heater	DYNA 300K BTU Heater
Direct Fired 400k BTU (LP/NG) Heater	FLAGRO F-400T
Direct Fired 600k BTU (K/DSL) Heater	MASTER MH-60V-GFA-A
Flameless Indirect Fired 600k BTU (K/DSL) Heater	THERMAL DYNAMICS TD600
Flameless Indirect Fired 1.2 Million BTU (K/DSL) Heater	THERMAL DYNAMICS TD1200
Indirect Fired 85k BTU Heater	DYNA KFA80H
Indirect Fired 500k BTU (K/DSL) Heater	THERMAL DYNAMICS TD500-IDF
Indirect Fired 1M BTU (K/DSL) Heater	ALLMAND MAXI-HEAT 1M BTU
Hydronic Surface Heater 385k BTU (K/DSL)	DRY AIR 400 GTS
Hydronic Surface Heater 620k BTU (DSL)	DRY AIR 650 GTS

EVENT AND SITE SERVICES

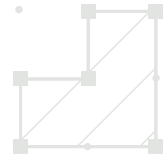

DIESEL GENERATOR

SHINDAIWA DGK15FL



EVENT AND SITE SERVICES
HANDWASHING STATION



SHINDAIWA
DGK15FL



ALLMAND
NLV3GR

EVENT AND SITE SERVICES

CLASS	MODEL
Portable Restroom	Satellite Industries AXSIS 6600Q
Hand Washing Station	Mobile Handwashing Station
12kW Diesel Generator	SHINDAIWA DGK15FL
3kW Light Plant, LED	ALLMAND NLV3GR 

 * Electric Powered Assets

FLUID SOLUTIONS

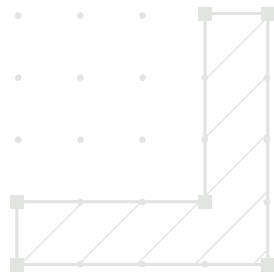
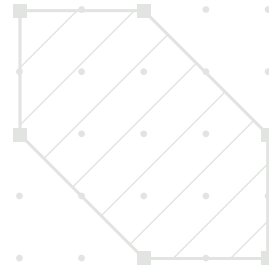



CENTRIFUGAL PUMP

ATLAS COPCO PAC H64



CENTRIFUGAL PUMPS

CLASS	MODEL	TYPE	MAX FLOW RATE	HORSEPOWER	MAX PUMP PRESSURE
2" Gas Trash Pump	WACKER NEUSON PT2	Centrifugal	165 gpm	5.5 hp	46 psi
2" Gas Dewatering Pump	WACKER NEUSON PG2A	Centrifugal	168 gpm	3.5 hp	38 psi
3" Gas Dewatering Pump	WACKER NEUSON PG3A	Centrifugal	290 gpm	5 hp	38 psi
3" Gas Trash Pump	MULTIQUIP QP3TH	Centrifugal	396 gpm	8 hp	41 psi
4" Diesel Trash Pump 49 HP	ATLAS COPCO PAC 44 HF	Centrifugal	1,320 gpm	49 hp	65 psi
4" Diesel Trash Pump 49 HP, Silent	PIONEER SAPP44S10L71-D2.9L4	Centrifugal	1,320 gpm	49 hp	65 psi
4" Diesel Trash Pump, Stainless	RWN 4NNTL-6.50BPT-SS	Centrifugal	1,320 gpm	49 hp	65 psi
4" x 3" Diesel Trash Pump, High Head	ATLAS COPCO PAC H43	Centrifugal	660 gpm	74 hp	130 psi
6" Diesel Trash Pump 74 HP	ATLAS COPCO PAC F66 KD	Centrifugal	2,640 gpm	74 hp	72 psi
6" x 3" Diesel Trash Pump, High Head	PIONEER PP63C17L71-4045HFC06	Centrifugal	1,100 gpm	142 hp	199 psi
6" x 4" Diesel Trash Pump, High Head	ATLAS COPCO PAC H64	Centrifugal	1,950 gpm	275 hp	216 psi
6" x 4" Diesel Trash Pump, High Head, Silent	ATLAS COPCO PAC H64-S	Centrifugal	1,950 gpm	275 hp	216 psi
6" Diesel Trash Pump 74 HP	RWN 6612T-0BPT	Centrifugal	2,800 gpm	74 hp	86 psi
6" Diesel Trash Pump 74 HP, Silent	PREMIER PUMP 6NNT-RP-TD2.9-T120	Centrifugal	2,800 gpm	74 hp	80 psi
6" Diesel Trash Pump, Stainless	RWN SS-6612T	Centrifugal	3,000 gpm	74 hp	86 psi
8" Diesel Trash Pump 120 HP	ATLAS COPCO PAC F88 PD	Centrifugal	3,950 gpm	120 hp	86 psi
8" Diesel Trash Pump 120 HP, Silent	ATLAS COPCO PAC F88 PD-S	Centrifugal	3,950 gpm	120 hp	86 psi
10" x 8" Diesel Trash Pump 325 HP, High Head	RWN 8NHTA-100BPT	Centrifugal	5,100 gpm	325 hp	151 psi
10" x 8" Diesel Trash Pump 325 HP, High Head, Silent	ATLAS COPCO PAC H108 JD-S	Centrifugal	6,400 gpm	325 hp	155 psi
12" Diesel Trash Pump 156 HP, Silent	ATLAS COPCO PAC 1212 JD-S	Centrifugal	7,210 gpm	156 hp	66 psi
12" x 8" Diesel Trash Pump, High Head	PREMIER PUMP 8NHT-RP-DC13	Centrifugal	7,500 gpm	550 hp	194 psi



CENTRIFUGAL PUMPS (CONTINUED)						
CLASS	MODEL		TYPE	MAX FLOW RATE	HORSEPOWER	MAX PUMP PRESSURE
4" Electric Trash Pump	ATLAS COPCO PAC 44 E	⚡	Centrifugal	1,230 gpm	50 hp	71 psi
6" Electric Trash Pump	ATLAS COPCO PAC 66 E	⚡	Centrifugal	2,640 gpm	75 hp	72 psi
8" Electric Trash Pump	PIONEER EPP88S12L71	⚡	Centrifugal	4,500 gpm	125 hp	260 psi
10" x 8" Electric Trash Pump, High Head	PIONEER EPP108S17L71	⚡	Centrifugal	6,500 gpm	350 hp	260 psi
12" Electric Trash Pump	ATLAS COPCO F1212E	⚡	Centrifugal	9,100 gpm	350 hp	113.4 psi

⚡ * Electric Powered Assets



DIAPHRAGM PUMPS

CLASS	MODEL	TYPE	MAX FLOW RATE	HORSEPOWER	MAX PUMP PRESSURE
4" Double Diaphragm Diesel Pump	MYERS-SETH A-DD4S/HA/T	Diaphragm	300 gpm	6.4 hp at 2,000 rpm	90 psi
6" Double Diaphragm Diesel Pump	MYERS-SETH A-DD6/HA/T	Diaphragm	600 gpm	10.3 hp at 2,000 rpm	60 psi
6" Double Diaphragm Diesel Pump, Silent	MYERS-SETH A-DD6/HA/SAFE	Diaphragm	600 gpm	10.3 hp at 2,000 rpm	60 psi
8" Double Diaphragm Diesel Pump	MYERS-SETH A-DD8/HA/T	Diaphragm	800 gpm	34 hp at 1,800 rpm	45 psi
2" Aluminum AOD	IR PD20A-AAP-CCC-B	Diaphragm	172 gpm	-	120 psi
3" Aluminum AOD	IR PD30A-AAP-CCC-C	Diaphragm	275 gpm	-	120 psi
2" Stainless Steel AOD	IR PD20A-ASS-STT-B	Diaphragm	172 gpm	-	120 psi
3" Stainless Steel AOD	IR PD30A-ASS-STT-C	Diaphragm	275 gpm	-	120 psi
2" Poly AOD	IR PD20P-FPS-PTT	Diaphragm	184 gpm	-	120 psi
3" Poly AOD	IR PD30P-DPS-PTT-A	Diaphragm	285 gpm	-	120 psi



SUBMERSIBLE PUMPS

CLASS	MODEL		TYPE	MAX FLOW RATE
1"-2" Electric Submersible Pump	WACKER NEUSON PST2	⚡	Submersive	52.8 gpm
3" Electric Submersible Pump	WACKER NEUSON PST3	⚡	Submersive	60.8 gpm
3" Electric Submersible Pump, Water	ATLAS COPCO WEDA D50	⚡	Submersive	310 gpm
3" Electric Submersible Pump, Sludge	ATLAS COPCO WEDA S30N	⚡	Submersive	230 gpm
4" Electric Submersible Pump	ATLAS COPCO WEDA L80N	⚡	Submersive	660 gpm
4" Electric Submersible Pump, Water	ATLAS COPCO WEDA D80H	⚡	Submersive	760 gpm
4" Electric Submersible Pump, Sludge	ATLAS COPCO WEDA S60N	⚡	Submersive	420 gpm
4" Electric Submersible Pump, Slurry	ATLAS COPCO WEDA L95N	⚡	Submersive	880 gpm
6" Electric Submersible Pump	ATLAS COPCO WEDA L100N	⚡	Submersive	1,320 gpm
8" Electric Submersible Pump, Water	ATLAS COPCO WEDA D95N	⚡	Submersive	3,000 gpm

⚡ * Electric Powered Assets



HYDRAULIC SUBMERSIBLE PUMPS AND HYDRAULIC POWER PACKS

CLASS	MODEL	MAX FLOW RATE
4" Hydraulic Submersible Pumpend	HYDRA-TECH S4TDHLI	900 gpm
6" Hydraulic Submersible Pumpend	HYDRA-TECH S6V	1,500 gpm
8" Hydraulic Submersible Pumpend	HYDRA-TECH S8TC	2,500 gpm
12" Hydraulic Submersible Pumpend	D&D 12T	5,250 gpm
74 HP Power Pack	HYDRA-TECH HT74DVD	30 gpm at 2,800 psi
205 HP Power Pack	D&D 800D	96 gpm at 2,500 psi



MYERS-SETH
MSP PP-150



MYERS-SETH
RL-200



THOMPSON
8RW-DDS-3.6

WELLPOINT DEWATERING PUMPS

CLASS	MODEL	HORSEPOWER	AIR HANDLING
6" Diesel Piston Dewatering Pump, Silent	MYERS-SETH MSP PP-150	10 hp	90 cfm
8" Diesel Rotary Dewatering Pump	MYERS-SETH RL-200	50 hp	180 cfm
8" Diesel Rotary Dewatering Pump	THOMPSON 8RW-DDS-3.6	74 hp	250 cfm
8" Diesel Rotary Dewatering Pump, Silent	THOMPSON 8RW DDS-3.6-X Canopy	74 hp	250 cfm
12" Diesel Rotary Dewatering Pump	THOMPSON 12R-DDS-3.6-X	74 hp	400 cfm
12" Diesel Rotary Dewatering Pump, Silent	THOMPSON 12R-DDS-3.6-X Canopy	74 hp	400 cfm



SELF CONTAINED MOBILE DUTY VARIABLE FREQUENCY DRIVES

CLASS	MODEL	VOLTAGE	AMPERAGE
10 HP VFD	FUJI MD010	-	-
25 HP VFD	YASKAWA DW-4025	480 V	40 A
30 HP VFD	FUJI MD030	-	-
50 HP VFD	FUJI MD050	-	75 A
100 HP VFD	FUJI MD100	460 V	176 A
200 HP VFD	FUJI MD200	480 V	253 A
350 HP VFD	FUJI MD350	480 V	415 A
600 HP VFD	FUJI MD600	-	-



ACCESSORY
LAYFLAT HOSE



ACCESSORY
BAUER PIPE
ACCESSORY
SUCTION HOSE



ACCESSORY
FLANGED FITTINGS

ACCESSORIES

CLASS	CLASS
Layflat hose 2"–12"	Oil & chemical hoses
TPU Layflat Hose 12"–16"	Stainless Steel Fittings
Bauer Pipe 4"–12"	Floats
Valves and fittings 1"–24"	Level Transducers
HDPE Pipe & Accessories	Pressure Transducers
Flow meters	Remote Monitoring
Composite & Cargo hose 2"–12"	

POWER SOLUTIONS

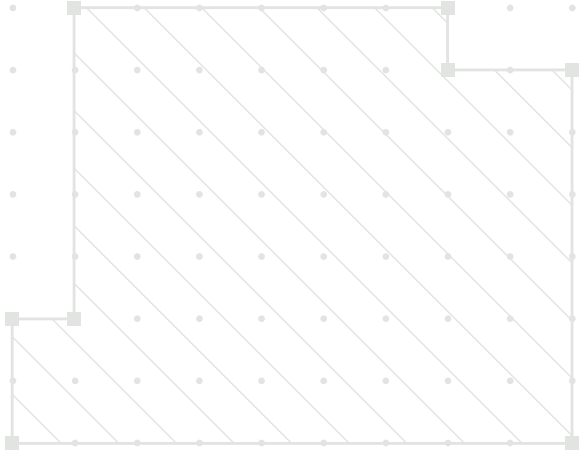
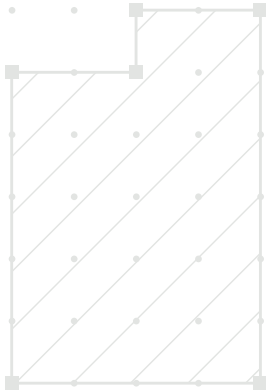

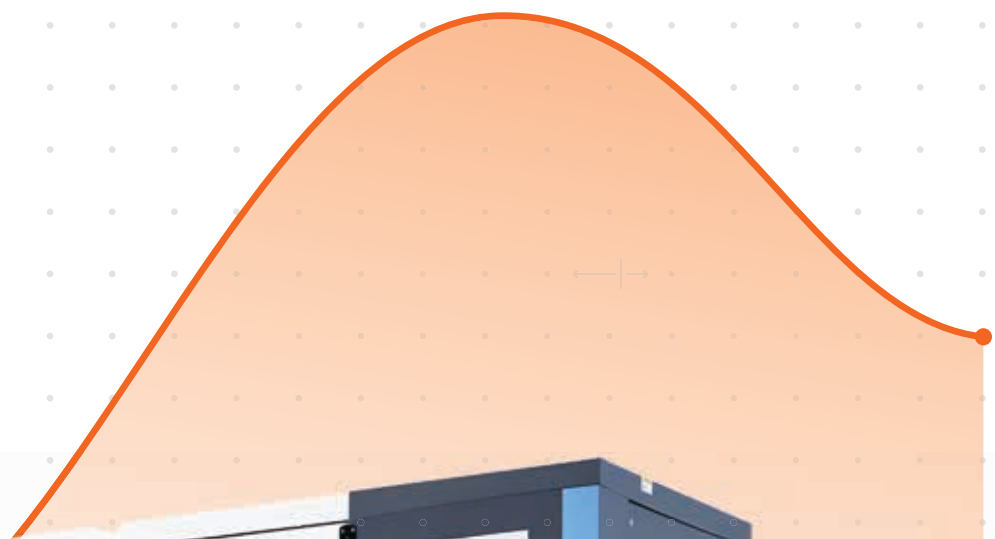
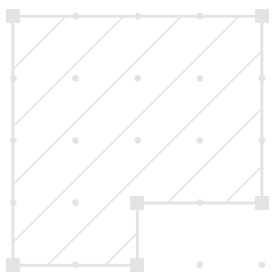

GENERATOR
ATLAS COPCO QAS330

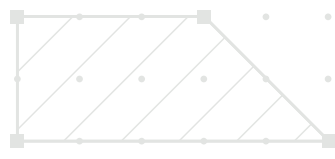
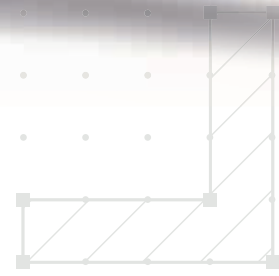



GENERATORS

CLASS	MODEL	MAX OUTPUT
20 kW Diesel Generator	AIRMAN SDG25S	20 kW
20 kW/25kVA Diesel Generator	WACKER NEUSON G25	20 kW
36 kW Diesel Generator	WACKER NEUSON G50	36 kW
36 kW/45 kVA Diesel Generator	ATLAS COPCO QAS45 CWK	36 kW
56 kW Diesel Generator	ATLAS COPCO QAS70	56 kW
80 kW Diesel Generator	ATLAS COPCO QAS90	80 kW
100 kW Diesel Generator	MULTIQUIP DCA125	100 kW
100 kW/125 kVA Diesel Generator	ATLAS COPCO QAS125	100 kW
120 kW Diesel Generator	ATLAS COPCO QAS150	120 kW
160 kW Diesel Generator	ATLAS COPCO QAS200	160 kW
200 kW Diesel Generator	ATLAS COPCO QAS250	200 kW
250 kW Diesel Generator	ATLAS COPCO QAS330	250 kW
500 kW Diesel Generator	ATLAS COPCO QAS625	500 kW
1,160 kW Diesel Generator	ATLAS COPCO QAC1500	1,160 kW
2,000 W Inverter Generator	GENERAC 2200i	2,200 kW



SIMPSON
70059



WACKER NEUSON
GP6600A



WACKER NEUSON
GPS9700V

PORTABLE GENERATORS

CLASS	MODEL	MAX OUTPUT
2kW – 4kW Portable Generator	SIMPSON 70059	4 kW
5kW – 7kW Portable Generator	WACKER NEUSON GP6600A	7 kW
9kW – 11kW Portable Generator	WACKER NEUSON GPS9700V	11 kW



TRYSTAR
TB-50AFT



TRYSTAR
TPATS-065MMMF-A



TRYSTAR
IL-046-VDE-27-LP

PANELS

CLASS	MODEL		MAX OUTPUT
Spider Box Panel, 50 Amp	TRYSTAR TB-50AFT	⚡	50 amp
Spider Box Feeder Panel, 200 Amp	TRYSTAR HTB-1DL-6P	⚡	200 amp
800 Amp Disconnect	GENERAL ELECTRIC FUSED SWITCH	⚡	800 amp
200 Amp Disconnect ATS	TRYSTAR TP-2DEHC-16P	⚡	200 amp
Automatic Transfer Switch, 600 Amp	TRYSTAR TPATS-065MMMF-A	⚡	600 amp
400 Amp I-Line Panel	TRYSTAR IL-046-VDE-27-LP	⚡	400 amp
800 Amp I-Line Panel	TRYSTAR IL-086-VDE-27-LP	⚡	800 amp
1,200 Amp I-Line Panel	TRYSTAR IL-126-VDE-45-LP	⚡	1,200 amp
30 kVA Mill Panel, 480-110 V	TRYSTAR TF-30KVA480-208SDC-CG-D	⚡	83.4 amp
45 kVA Transformer, 480/208 V	TRYSTAR TF-45KVA480-208SDC-M-F	⚡	45 kVA
75 kVA Transformer, 480/208 V	TRYSTAR TF-75KVA480-208SDC-M-F	⚡	75 kVA
150 kVA Transformer, 480/208 V	TRYSTAR TF-150KVA480-208SDC-M-F	⚡	150 kVA
Transformer 2,500 kVa, Multi-Tap, Medium Voltage	VANTRAN 2500MTT	⚡	2,500 kVA

⚡ * Electric Powered Assets

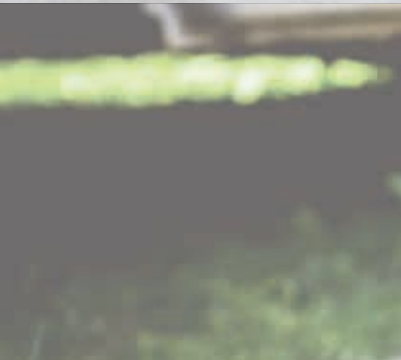
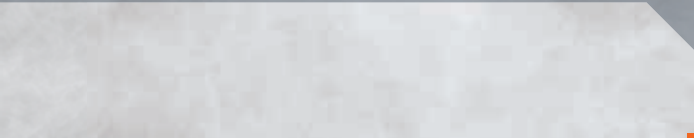



TOOLING SOLUTIONS

Mobile Tool Trailers

Compressed Air

Electric and Hydraulic Power Tools

Attachments

Storage Tanks and Containers

Welding, Cutting and Pipe Fabrication

Industrial Goods



PIPE BEVELER
RIDGID 8500



PAVEMENT BREAKER
DEWALT D25980K



CUT-OFF MACHINE
STIHL TS 420



DEMOLITION HAMMER
HILTI TE 1000-AVR





ELECTRIC CRIMPER
MILWAUKEE 2877-22



Mobile Tool Trailer

Mobile Tool Crib

MOBILE TOOL TRAILERS

Our Mobile Tool Trailers offer a fully customizable suite of tools and supplies to support a wide range of project needs. All trailers are customized to support specific job requirements and arrive staffed with dedicated Tool Technicians to assist with inventory tracking.

Consult with your EquipmentShare account manager to learn more about how our Tool Trailers can help you get the job done.



CORE DRILL
HILTI DD 250-CA



COMPRESSED AIR

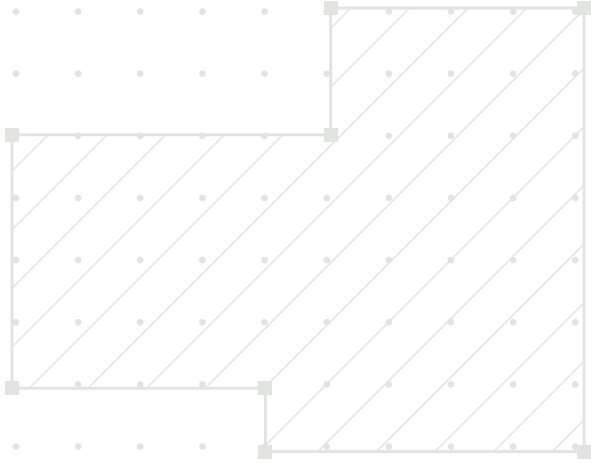

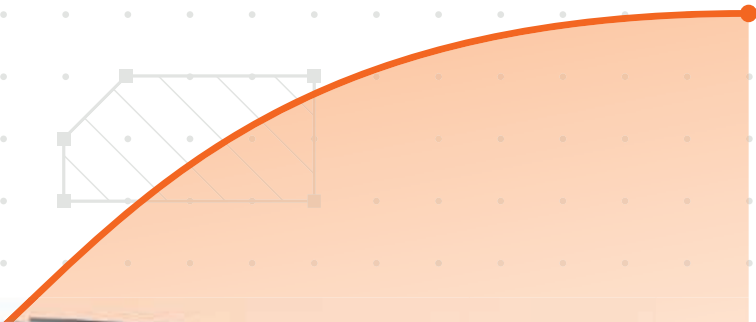
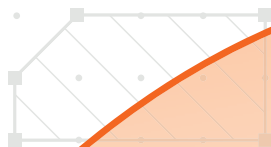

AIR COMPRESSOR

ATLAS COPCO XAS 1800





ATLAS COPCO
XAS 110



ATLAS COPCO
XATS 400



ATLAS COPCO
XAS 950

AIR COMPRESSORS

CLASS	MODEL	WORKING PRESSURE	FREE AIR DELIVERY
185 CFM Electric Air Compressor	ATLAS COPCO E-AIRH185 ⚡	72–175 psi	192 cfm
250 CFM Electric Air Compressor	ATLAS COPCO E-AIRH250 ⚡	72–174 psi	178–233 cfm
450 CFM Electric Air Compressor	ATLAS COPCO E-AIRH450 ⚡	72–188	455 cfm
1,100 CFM Electric Air Compressor	ATLAS COPCO E-AIRV1100 ⚡	72–205	1,285 cfm
100–120 CFM Diesel Air Compressor	ATLAS COPCO XAS 110	100–128 psi	110 cfm
185 CFM Diesel Air Compressor	ATLAS COPCO XAS 188 CWK	60–125 psi	190 cfm
185 CFM Diesel Air Compressor	AIRMAN PDS185S-6E1	100–120 psi	185 cfm
375–425 CFM Diesel Air Compressor	SULLAIR 375H	150 psi	375 cfm
400 CFM Diesel Air Compressor IQ	ATLAS COPCO XATS 400	58–150 psi	395 cfm
750 CFM Diesel Air Compressor IQ	ATLAS COPCO XAS 900	100–150 psi	750–867 cfm
750 CFM Diesel Air Compressor High Pressure	DOOSAN XHP750WCU-T4F	140–365 psi	750 cfm
900 CFM Diesel Air Compressor IQ	ATLAS COPCO XAS 950	100–200 psi	755–950 cfm
1,170 CFM Diesel Air Compressor High Pressure	DOOSAN XHP1170WCU-T4F	365 psi	1,170 cfm
1,600 CFM Diesel Air Compressor IQ	ATLAS COPCO XAS 1800	100–200 psi	1,405–1,810 cfm

⚡ * Electric Powered Assets



COMPRESSED AIR TOOLS

CLASS	MODEL	AIR CONSUMPTION	BLOWS PER MINUTE / TORQUE
30lb Breaker	MICHIGAN PNEUMATIC 30-1	39 cfm	1,550 bpm
60lb Breaker	MICHIGAN PNEUMATIC TPB60-118	58 cfm	1,400 bpm
90lb Breaker	MICHIGAN PNEUMATIC TPB90-118	75 cfm	1,200 bpm
Chipping Hammer	MICHIGAN PNEUMATIC CH-3R	32 cfm	2,100 bpm
Rivet Buster	MICHIGAN PNEUMATIC 133-ORANGE-NEP	35 cfm	1,140 bpm
Wrench Impact Air 3/4"	MICHIGAN PNEUMATIC 750SS	58 cfm	1,800 ft/lb Max Torque
Wrench Impact Air 1"	MICHIGAN PNEUMATIC 4940B2	⚡ 70 cfm	2,800 ft/lb Max Torque
20' Jet Tank Fan	MICHIGAN PNEUMATIC 20262	260 cfm	-
8' Air Horn	MICHIGAN PNEUMATIC 8-AM	142 cfm	-
15 Gallon 8 Outlet Air Manifold	MICHIGAN PNEUMATIC 15G-8P	-	-

ELECTRIC AND HYDRAULIC POWER TOOLS

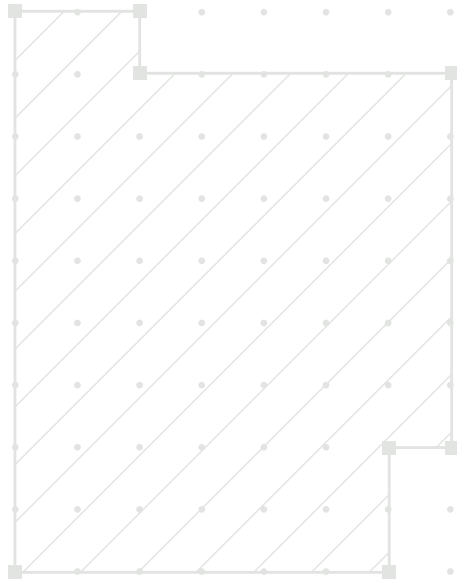

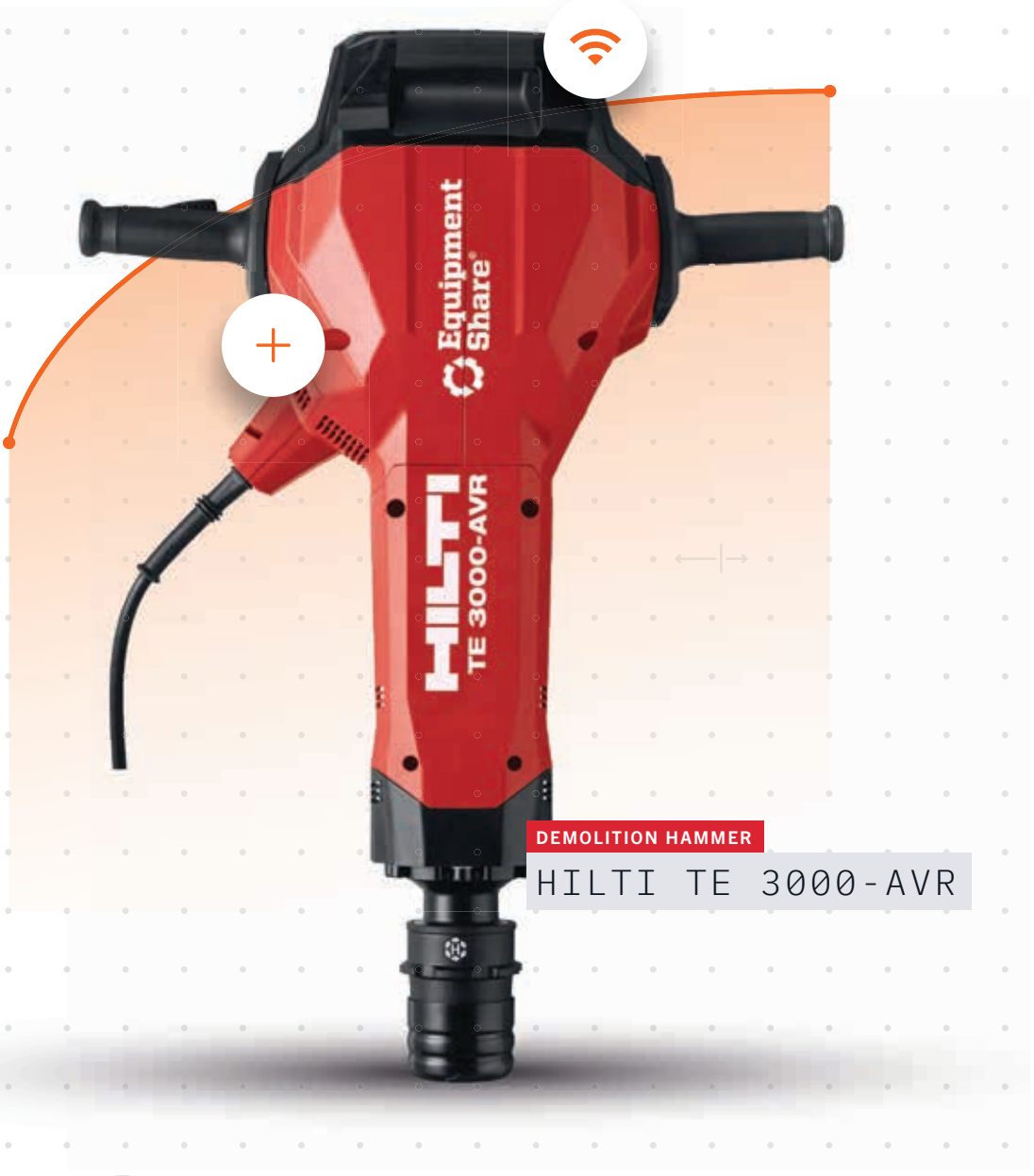
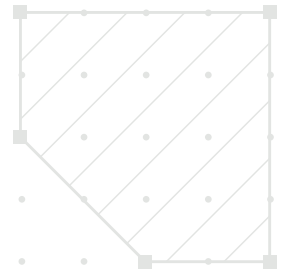

DEMOLITION HAMMER

HILTI TE 3000-AVR





ELECTRIC POWER TOOLS

CLASS	MODEL		TYPE	OUTPUT
Midsize Combination Hammer Drill - SDS MAX	HILTI TE 50-AVR	⚡	Rotary Hammer	360 rpm
Large Combination Hammer Drill - SDS MAX	HILTI TE 70-AVR	⚡	Rotary Hammer	360 rpm
35 lb Demolition Hammer, Electric	HILTI TE 1000-AVR	⚡	Concrete Breaker	1,950 ipm
65 lb Demolition Hammer, Electric	HILTI TE 3000-AVR	⚡	Jack Hammer	850 ipm
6" Core Drill Kit, Stand and Vacuum	HILTI DD150	⚡	Core Drill	3,070 rpm
12" Core Drill Kit, Stand and Vacuum	HILTI DD250	⚡	Core Drill	2,220 rpm
Wrench Torque Hydraulic Low Profile 2K Drive	TORCUP TX-2, TXU-2	⚡	Hydraulic Torque Wrench	Maximum Torque 1,928 ft/lbs
Wrench Torque Pump Air Driven Hydraulic	TORCUP AP1000	⚡	Hydraulic Torque Wrench Pump	100 psi / 50 cfm
Wrench Torque Gun 1' Air 2K	TORCUP RP-2000	⚡	Pneumatic Torque Wrench	Maximum Torque 2,015 ft/lbs
Wrench Torque Gun 3/4' Cordless	TORCUPVT-1000KIT	⚡	Electric Torque Wrench	Maximum Torque 1,000 lbf-ft
Punch Steel 35 Ton Hydraulic	ENERPAC SP35	⚡	Hydraulic Punch	Capacity 35 (imperial tons)
Nut Splitter 15 Ton Hydraulic	ENERPAC NSH2432	⚡	Hydraulic Nut Splitter	Capacity 15 (imperial tons)
Flange Spreader Wedge 15 Ton Manual	ENERPAC FSH14	⚡	Hydraulic Industrial Spreader	Capacity 14 (imperial tons)
Punch Knockout Set 1/2" to 4" Hydraulic	GREENLEE 7310SB	⚡	Hydraulic knockout kit	11 ton Hydraulic Force
Crimper Cable Cordless Dieless	MILWAUKEE 2877-22	⚡	Dieless Crimper	750 MCM, 18 V Battery

⚡ * Electric Powered Assets



ELECTRIC POWER TOOLS (CONTINUED)

CLASS	MODEL	TYPE	OUTPUT
Bandsaw Cordless Deepcut 5"	MILWAUKEE 2729-22HD ⚡	Portable Band Saw Kit	44 7/8" Blade Lg, 18 V Battery
M18™ REDLITHIUM™ XC5.0 Extended Capacity Battery Pack	MILWAUKEE 48-11-1850	Rechargeable Battery Pack	18 V
1/2" VSR™ Pistol Grip Drill	DEWALT DWD220	Electric Drill	10.5 amp motor, 0–1,250 rpm
Drill Hammer Rotary 1 3/4" Cordless SDS Max	DEWALT DCH614X2	Rotary Hammer	1450–2900 bpm
Impact Socket 3/4"	WRIGHT 6834	Impact Socket	DR X 1-1/16" STD
Impact Socket 3/4"	PROTO J07520L	Impact Socket	DR X 1-1/4" DW
Impact Socket 3/4"	PROTO J07523L	Impact Socket	DR X 1-7/16" DW
Impact Wrench 3/4"	MILWAUKEE 2864-22 ⚡	Impact Wrench	1,200 ft-lb Fastening Torque, 1,500 ft-lb Breakaway Torque
Manual Torque Wrench 1/2"	PROTO J6014C	Micrometer Torque Wrench	Torque Range: 50 ft-lb to 250 ft-lb
Manual Torque Wrench 3/4"	PROTO J6020AB	Micrometer Torque Wrench	Torque Range: 120 ft-lb to 600 ft-lb
Cordless Angle Grinder, 4" to 5"	MILWAUKEE 2780-22HD	Angle Grinder	No Lock, 9 V Battery
Electric Angle Grinder, 4 1/2" to 5"	DEWALT DWE402N	Angle Grinder	No Lock, 11,000 RPM
Electric Angle Grinder, 6"	DEWALT DWE46266N	Angle Grinder	13 amp 9,000 RPM
Die Grinder, 1 1/2"	DEWALT DWE4887N	Die Grinder	4.2 amp, 25,000 RPM

ATTACHMENTS

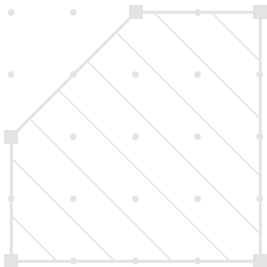
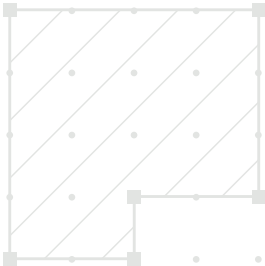

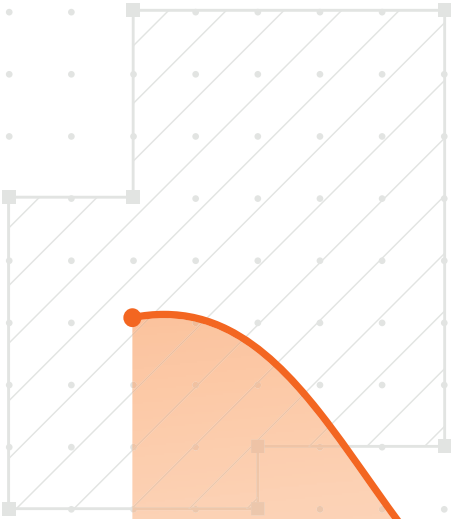

HYDRAULIC BREAKER

PALADIN SFB1500

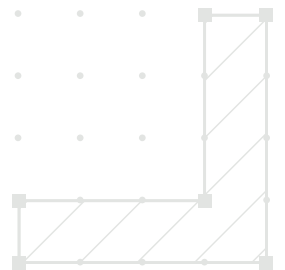
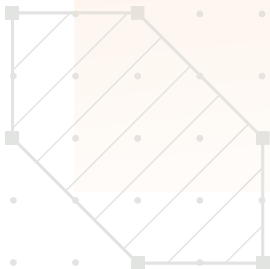



COMPACT TRACK AND SKID LOADER ATTACHMENTS

CLASS	CLASS
Smooth Bucket 68"-84"	Concrete Bucket with Chute
Tooth Bucket 68"-84"	Post Driver, CTL
Auger, Ride-on Mini Skid Loader	Sand Bagger Attachment, CTL
Auger, Standard Flow	Angled Snow Blade 84", CTL
Hydraulic Breaker 250 lbs, Ride-on Mini Skid Steer	Snow Blade 78", CTL
Hydraulic Breaker 500 lbs	Snow Blade 96", CTL
Brush Cutter 68"-72", Standard Flow	Snow Pusher 144", CTL
Brush Cutter 68"-72", High Flow	Sweeper 60" Front Brush, CTL
Finishing Mower 68"-72"	Sweeper 72" Front Brush, CTL
Asphalt Cold Planer 18", High Flow	Sweeper 84" Front Brush, CTL
Asphalt Cold Planer 24", High Flow	Sweeper 72" Debris Hopper and Brush, CTL
Scrap Grapple Bucket 76"-84"	Sweeper 84" Debris Hopper and Brush, CTL
Brush Grapple Bucket 76"-84"	Trencher 36" Bar, Ride-on Mini Skid Steer
Landscape Rake, CTL Attachment	Trencher 36" Bar, CTL
Powered Box Rake, CTL Attachment	
Soil Conditioner 48", Ride-on Mini Skid Steer	
Soil Conditioner 74"-78"	
Soil Conditioner 86"-92"	
Tiller 68"-72", CTL	
Smooth bucket 36", Ride-on Mini Skid Steer	
Tooth bucket 36", Ride-on Mini Skid Steer	
Pallet Forks 36", Ride-on Mini Skid Steer	
Pallet Forks 48", CTL	
Pallet Forks 72", CTL	



HYDRAULIC BREAKER
1,000 LBS



HYDRAULIC BREAKER
500 LBS



AUGER
5,000-14,000 LBS

EXCAVATOR ATTACHMENTS

CLASS	CLASS
Buckets 12"–36", Mini Excavator and Backhoes	Compaction Wheel 12"–18", Mini Excavator and Backhoes 15,000–19,000 lbs
Bucket 18"–42" HD, Excavator 25,000–35,000 lbs	Compaction Wheel 18"–24", Excavator 25,000–39,000 lbs
Bucket 24"–48" HD, Excavator 38,000–39,000 lbs	Compaction Wheel 18"–24", Excavator 45,000–55,000 lbs
Bucket 24"–54" HD, Excavator 45,000–55,000 lbs	Compaction Wheel 18"–36", Excavator 56,000–75,000 lbs
Bucket 24"–54" HD, Excavator 56,000–75,000 lbs	Compaction Wheel 18"–36", Excavator 80,000–85,000 lbs
Bucket 24"–60" HD, Excavator 80,000–85,000 lbs	Hydraulic Plate Compactor 6,500 lbs, Mini Excavator and Backhoes 15,000–19,000 lbs
Bucket 36"–84" HD, Excavator 110,000–120,000 lbs	Hydraulic Plate Compactor 11,500 lbs, Excavator 56,000–75,000 lbs
Hydraulic Breaker 250 lbs, Mini Excavator 2,500–4,000 lbs	Padding Bucket 48", Excavator 45,000–55,000 lbs
Hydraulic Breaker 500 lbs, Mini Excavator 5,000–14,000 lbs	Padding Bucket 60", Excavator 80,000–85,000 lbs
Hydraulic Breaker 1,000 lbs, Mini Excavator and Backhoes 15,000–19,000 lbs	Grapple Attachment
Hydraulic Breaker 1,500–2,000 lbs, Excavator 25,000–35,000 lbs	Auger, Mini Excavator 5,000–14,000 lbs
Hydraulic Breaker 3,000 lbs, Excavator 25,000–35,000 lbs	Auger, Mini Excavator and Backhoes 15,000–19,000 lbs
Hydraulic Breaker 4,000–5,000 lbs, Excavator 38,000–55,000 lbs	
Hydraulic Breaker 5,000 lbs, Excavator 56,000–65,000 lbs	
Hydraulic Breaker 8,000 lbs, Excavator 56,000–75,000 lbs	
Hydraulic Breaker 10,000 lbs, Excavator 80,000–85,000 lbs	
Hydraulic Breaker 12,000 lbs, Excavator 80,000–85,000 lbs	
Hydraulic Breaker 12,000 lbs, Excavator 110,000–120,000 lbs	
Bucket 24" V-Bottom Rock, Excavator 45,000–55,000 lbs	
Bucket 24"–36" V-Bottom Rock, Excavator 56,000–75,000 lbs	
Bucket 24"–36" V-Bottom Rock, Excavator 80,000–85,000 lbs	
Bucket 24"–36" V-Bottom Rock, Excavator 110,000–120,000 lbs	
Bucket 60" Smooth Grading, Excavator 45,000–55,000 lbs	
Compaction Wheel 12"–18", Mini Excavator 5,000–14,000 lbs	



BUCKET
2.75 CU.YD SMOOTH



WHEEL LOADER
GRAPPLE BUCKET



FORK SET
96" CARRIAGE

WHEEL LOADER ATTACHMENTS

CLASS

Bucket 2.75 cu. yd Smooth, Wheel Loader 150–195 HP

Bucket 2.75 cu. yd Tooth, Wheel Loader 150–195 HP

Bucket 3 cu. yd Smooth, Wheel Loader 150–195 HP

Bucket 3 cu. yd Tooth, Wheel Loader 150–195 HP

Bucket 4 cu. yd Smooth, Wheel Loader 150–195 HP

Bucket 4 cu. yd Tooth, Wheel Loader 150–195 HP

Bucket 4.25 cu. yd Smooth, Wheel Loader 230–255 HP

Bucket 4.25 cu. yd Tooth, Wheel Loader 230–255 HP

Bucket 2–3 cu. yd, Side Dump, Wheel Loader 150–195 HP

Grapple Bucket, Wheel Loader

Fork Set 60" Carriage, Wheel Loader 150–195 HP

Fork Set 96" Carriage, Wheel Loader 150–195 HP

Fork Set 60" Carriage, Wheel Loader 230–255 HP

Fork Set 96" Carriage, Wheel Loader 230–255 HP



ROTATOR CARRIAGE
48"



PIPE GRAPPLE
96"



DUMP HOPPER
1.5 CU.YD

MATERIAL HANDLING ATTACHMENTS

CLASS	CLASS
Fork Set Carriage, Telehandler	Adjustable Spreader Bar 8'-12'
Swing Carriage, 5,000 lbs Telehandlers	Magni Jib Winch, 5.25 Rotator
Swing Carriage, 6,000-7,000 lbs Telehandlers	Magni Lifting Hook, 5.25 Rotator
Swing Carriage, 8,000-9,000 lbs Telehandlers	Winch 6-10 Ton, Telehandler
Swing Carriage, 10,000-12,000 lbs Telehandlers	Carpet Pole
Rotator Carriage 48" for Magni 5.25	Dump Hopper 1.0 cu. yd, Steel w/ Castors & Fork Pockets
Rotator Carriage 72" for Magni 5.25	Dump Hopper 2.0 cu. yd, Steel w/ Castors & Fork Pockets
Pipe Grapple 96", 10,000-12,000 lbs Telehandlers	
Pipe Grapple 96", 20,000-29,000 lbs Telehandlers	
Bucket 78"-86", Telehandler Slide-on Forks	
Bucket 68"-74", Telehandler Slide-on Forks	
Bucket 90"-96", Telehandler Slide-on Forks	
Bucket 60"-67", Telehandler Slide-on Forks	
Dump Hopper 0.5 cu. yd, Steel w/ Castors & Fork Pockets	
Dump Hopper 1.5 cu. yd, Steel w/ Castors & Fork Pockets	
Dump Hopper 2.5 cu. yd, Steel w/ Castors & Fork Pockets	
Steel Trash Box, 4' x 5' x 5'	
Steel Trash Box, 4' x 5' x 7'	
Lifting Hook, 4,000 lbs	
Lifting Hook, 10,000-12,000 lbs	
Lifting Hook, 20,000 lbs	
Lifting Hook, 32,000 lbs	
Extendable Jib, 6'-12' Slide-on Forks	
Fixed Jib, 12' Manufacturer Specific Direct Mount	

STORAGE TANKS AND CONTAINERS





CONNEX BOXES

CLASS	MODEL
Connex Box, 8' x 8' x 20'	8' x 20' Container
Connex Box, 8' x 8' x 40'	8' x 40' Container



FLUID TANKS

CLASS	MODEL
Frac Tank	DRAGON 10K Mini Frac Tank



FUEL CELLS

CLASS	MODEL
250 Gallon Double Wall Fuel Tank Trailer	WESTERN GLOBAL FCP250
500 Gallon Double Wall Fuel Tank	WESTERN GLOBAL 20TCG(G)W-NA
1,000 Gallon Double Wall Fuel Tank	WESTERN GLOBAL 50TCG



GENERIC
GANG BOX



GENERIC
PRINT SHACK



GENERIC
TOOL CHEST

JOB BOX

CLASS	MODEL
-------	-------

Gang Box	Generic
----------	---------

Print Shack	Generic
-------------	---------

Tool Chest	Generic
------------	---------

WELDING, CUTTING AND PIPE FABRICATION

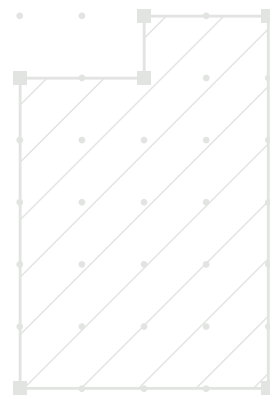
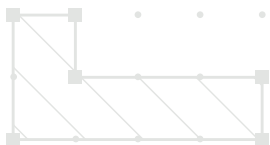

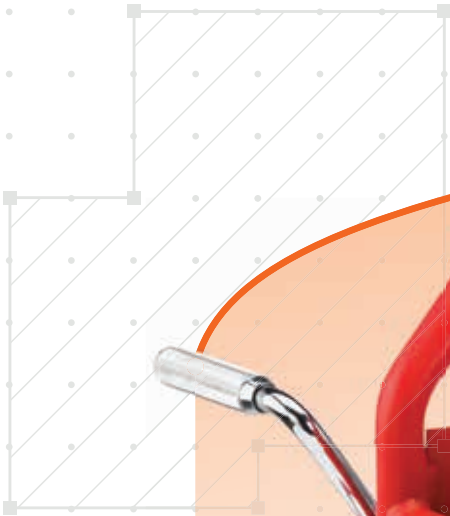
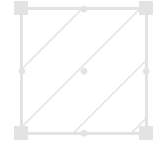

PIPE BEVELER

RIDGID B-500





SHINDAIWA
DGW400MDL



LINCOLN ELECTRIC
AIR VANTAGE 566



MILLER ELECTRIC
CST-280

ENGINE DRIVEN WELDERS

CLASS	MODEL	WEIGHT
200/200 AMP Dual Operator Welder	LINCOLN DUAL MAVERICK 200/200X	1,160 lbs
400 AMP Dual Operator Diesel Welder	SHINDAIWA DGW400MDL	999 lbs
300–400 AMP Diesel Welder	LINCOLN ELECTRIC VANTAGE 322	1,035 lbs
500 AMP AIR PAK Welder	LINCOLN ELECTRIC AIR VANTAGE 566	1,737 lbs
500 AMP CC/CV Diesel Welder	LINCOLN ELECTRIC VANTAGE 549	1,662 lbs
300–400 AMP Gasoline Welder	LINCOLN ELECTRIC RANGER 330MPX	446 lbs
Welder Propane 250 to 300 Amp	LINCOLN ELECTRIC Ranger 305 LPG	480 lbs
Welder Arc Inverter 280 Amp Boom	MILLER ELECTRIC CST-280 ⚡	41 lbs



LINCOLN ELECTRIC
POWER MIG 210MP

ELECTRIC WELDERS

CLASS	MODEL	WEIGHT
Welder Multi-Process	LINCOLN POWER MIG 210MP ⚡	40 lbs



LINCOLN ELECTRIC
LN-25X

SUITCASE WELDERS

CLASS	MODEL	WEIGHT
Wire Feeder Suitcase Welder	LINCOLN ELECTRIC LN-25X ⚡	37 lbs



MILLER ELECTRIC
MAXSTAR 210



MILLER ELECTRIC
DYNASTY 210 DX



LINCOLN ELECTRIC
FLEXTec 350X

INVERTER WELDERS

CLASS	MODEL	WEIGHT
Welder Arc Inverter 210 Amp Stick/Tig	MILLER ELECTRIC MAXSTAR 210 ⚡	38 lbs
Welder Tig 200 Amp	MILLER ELECTRIC DYNASTY 210 DX ⚡	47 lbs
350 AMP CC/CV Inverter Welder	LINCOLN ELECTRIC FLEXTec 350X ⚡	84 lbs
Welder Rack 350 Amp 4 Pack	LINCOLN ELECTRIC K3402-2 ⚡	620 lbs
Welder Rack 350 Amp 6 Pack	LINCOLN ELECTRIC K4277-1 ⚡	830 lbs
Welder Rack 350 Amp 6 Pack w/Dist Panel	TRYPSTAR 6XWLDK-350-9KVA-WG ⚡	425 lbs



LINCOLN ELECTRIC
TOMAHAWK 375 AIR



LINCOLN ELECTRIC
TOMAHAWK 1000

PLASMA CUTTERS

CLASS	MODEL	WEIGHT
Cutter Plasma 3/8" Capacity	LINCOLN ELECTRIC TOMAHAWK 375 Air ⚡	40 lbs
Cutter Plasma 1" Capacity	LINCOLN ELECTRIC TOMAHAWK 1000 ⚡	45 lbs



TRYPSTAR

TSWC200R50-BKM-BKF

WELDING ACCESSORIES

CLASS	MODEL	SIZE
Welding Lead 50' 2-0	TRYPSTAR TSWC200R50-BKM-BKF	2/0 AWG



PIPE THREADING

CLASS	MODEL	WEIGHT
Pipe Threader Powered 1/8" - 2"	RIDGID 535 ⚡	260 lbs
Pipe Threader Powered 1/8" - 2"	RIDGID 700 ⚡	25 lbs



PIPE BEVELING

CLASS	MODEL	WEIGHT
Pipe Beveler Electric Portable	RIDGID B-500 ⚡	52 lbs
Pipe Beveler Saddle 12" – 20"	MATHEY 3SA ⚡	50 lbs

INDUSTRIAL GOODS

We carry a full offering of industrial goods, including:

Tie wire	Sawzall Blades
Antifreeze	Tyvek Chem Suits
Magid Gloves	Spoggles
Small Headlights	Squencher freeze pops
Grinding Discs	Water

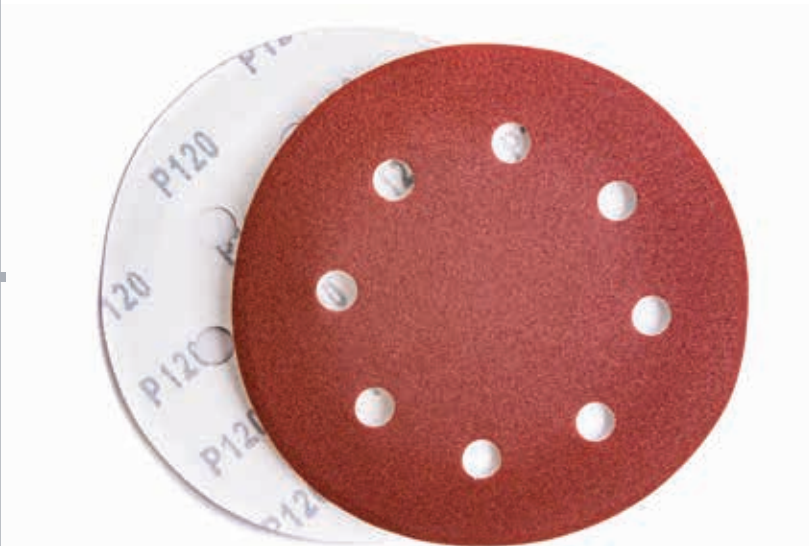



MOST PURCHASED INDUSTRIAL GOODS

CLASS	MODEL
Pry Bar 36"	CENTRAL FORGE 1222T
Combination Wrench 1-1/16"	PROTO J1234ASD
Combination Wrench 1-1/4"	WRIGHT 1140
Combination Wrench 1-7/16"	PROTO J1246
Combination Wrench 7/8"	WRIGHT 1128
Steel Sledge Hammer, 4 lb	AMES 1196900
Cable Extension Cord 100'	CENTURY D11712100YL
Impact Socket 3/4"	PROTO J07523L
Channel Lock Pliers 12"	CHANNELLOCK CHK440



EquipmentShare offers best-in-class customer service to help you every step of the way. Our representatives are available by phone, email and chat to solve problems and find solutions.



Scan to visit our website or email industrial.supplies@equipmentshare.com to learn more.

OUR PARTNERS



Leif's construction insurance experts analyze your exposures and create a tailored insurance program that helps you protect your operations, increase ROI and win more contracts.

An equipment telematics solution such as T3 by EquipmentShare can turn your data into insights that help you:

- Improve operator safety
- Anticipate mechanical issues
- Recover lost or stolen equipment

These insights can also reduce your risk of loss – which improves your claims experience and qualifies you for Leif's proprietary discounts of up to 50%.

Leif specializes in:

- Equipment insurance
- Commercial auto insurance
- Surety bonds
- Workers' compensation
- General liability
- Builder's risk
- In-house bond underwriting
- Safety and claims consulting
- Construction risk transfer
- Contract review and COIs

Leif's service promise to you includes:

- Eliminating coverage gaps and quickly securing new policies
- Partnering with strong carriers to offer the best program available
- Responding quickly to calls, texts, and chats during business hours
- Offering after-hours claims consultation for 24/7 emergency support
- Delivering most COIs within two business hours and bonds overnight
- Creating a strategy to maximize your bond capacity for growth

Visit leifassurance.com for more information.





Bevel Financial was built to help you achieve your business goals. Access comprehensive funding solutions across all of your business needs with one partner. Gain a competitive edge with Bevel Financial's simple and accelerated financing solutions.

Your business financing needs are our top priority. Bevel understands the urgency and importance of securing the right terms at the right time. Our approach is designed for you. Now you can get flexible, long-term financing solutions designed to honor the useful life of your equipment and secure the lowest monthly payment in the market.

Bevel aims to make the financing process quick, friendly and easy to understand. The Bevel team connects you with the ideal funding solution to accelerate the funding process, making it easy to scale your fleet and bring transparency to lending.

For fast, efficient funding, call Bevel today. Bevel has assisted in finding more than \$500 million in financing for businesses like yours. Apply today to give your business a competitive edge.

For more information, please contact lending@bevelfinancial.com
(888) 808-7686



LOCATIONS

ALABAMA	Birmingham ²	▲ □	CONNECTICUT	Hartford	▲ □	KENTUCKY	Calvert City	□	
	Huntsville ²	□ ▢		Louisville	□				
	Mobile ²	▲ □ ▢		DELAWARE	Delmar	▲ □	LOUISIANA	Alexandria	▲
ARIZONA	Phoenix ³	▲ □ ▢	FLORIDA		Apopka	□		Baton Rouge ²	▲ □ ▢
	Phoenix - W	□			Fort Myers	□		Lafayette	□
	Tucson	□			Jacksonville ²	▲ □		Lake Charles	□
	Yuma	□			Lakeland ²	▲ □ ▢		Monroe	□
ARKANSAS	El Dorado ²	□ ▢			Miami	▲ □	New Orleans	□	
	Fort Smith	▲ □			Orlando ²	▲ □	Shreveport	□	
	Little Rock	□			Palmetto	□	MARYLAND	Baltimore ²	□ ▢
	Osceola	□			Panama City	□		MICHIGAN	Detroit
	Pine Bluff	□			Sanford	□	Grand Rapids		▲ □
	Springdale	□			Tallahassee	□	MINNESOTA	Minneapolis	▲ □
	Texarkana	□		Tampa	□	MISSISSIPPI		Jackson	□
CALIFORNIA	Bakersfield ²	▲ □	GEORGIA	Atlanta ²	▲ □ ▢		Olive Branch	▲ ▢	
	Colton	▲		Perry	□	MISSOURI	Cape Girardeau	□	
	Fontana	□		Savannah ²	□ ▢		Columbia	□	
	Lake Forest	□	IDAHO	Boise	□		Joplin	□	
	Lancaster	□		Idaho Falls	□		Kansas City	□	
	Long Beach	▢	ILLINOIS	Chicago - SW	▲ □ ▢		Springfield	□	
	Madera	□		INDIANA	Indianapolis ²	▲ □	St. Louis	□	
	Martinez	▢	IOWA		Algona	□	MONTANA	Billings	□
	Newark	▲ □		Sioux City	□	NEBRASKA		Omaha	□
	Richmond	□	KANSAS	Elwood	□		NEVADA	Las Vegas ²	▲ □
	Sacramento	▲ □		Garden City	□	Reno		□	
San Diego ²	▲ □	Topeka		□	NEW JERSEY	Camden	▲ □		
COLORADO	Colorado Springs	□		Wichita		▲ □	Newark	▢	
	Denver ²	▲ ▢	KENTUCKY			South Plainfield	▲ □		
	Denver - N	□							
	Denver - S	□							
	Grand Junction	□							
Pueblo	□								

NEW MEXICO	Albuquerque	□
	Carlsbad	□
	Gallup	□
NORTH DAKOTA	Williston	▲□
OHIO	Cincinnati ²	□□
	Columbus	▲□
	Toledo	□
OKLAHOMA	Ardmore	□
	Oklahoma City	□
	Tulsa ²	▲□□
OREGON	Eugene	□
	Portland ²	▲□□
PENNSYLVANIA	Pittsburgh	▲□
SOUTH CAROLINA	Anderson	□
	Charleston	□
	Columbia	□
	Jackson	□
SOUTH DAKOTA	Rapid City	□
TENNESSEE	Chattanooga	□
	Knoxville	▲□
	Memphis	□
	Nashville	□

TEXAS	Abilene	□
	Amarillo	□
	Angleton	□
	Austin	▲□
	Bay City	□
	Baytown	□
	Beaumont ²	▲□
	Bryan	□
	Corpus Christi ³	▲□□
	Dallas	□
	Dallas - NE	□
	El Paso	□
	Ferris	□
	Fort Worth	□
	Fort Worth - S	▲□
	Harlingen	□
	Houston ³	▲□□
	Houston - SW	□
	Katy	□
	Laredo	□
	Lubbock	□
	McKinney	□
	Midland ²	▲□
	Odessa	□
	Pasadena	□
	Port Arthur	□
	San Angelo	□
	San Antonio	□
	San Antonio - NW	▲□
	Sherman	□
	Texas City	□
	Tyler	▲□
	Victoria	□
Waco	□	
Wichita Falls	□	

UTAH	Provo	□
	Salt Lake City	▲
VIRGINIA	Catlett	▲□
	Emporia	□
	Richmond ²	▲□
	Stafford	□
	Virginia Beach	▲□
WASHINGTON	Pasco	□
	Seattle	▲□
	Spokane ²	▲□
	Yelm	□
WISCONSIN	Milwaukee	□
WYOMING	Casper	▲□

*Numbers indicate number of locations in that city.

**Icons indicate which divisions are represented in that city.

DIVISIONS



ADVANCED SOLUTIONS



CORE SOLUTIONS



TOOLING SOLUTIONS



SCAN FOR THE MOST UP-TO-DATE LOCATIONS LIST.

270 LOCATIONS AND

GROWING NATIONWIDE



SCAN FOR THE MOST
UP-TO-DATE LOCATIONS LIST.

WEB
EQUIPMENTSHARE.COM

TEL
(888) 80-RENTS

Follow us on social media:

